

**AMK
RACING KIT
4 wheel drive
"Formula Student Electric"**

Version: 2017/02

Part no.: 205481

Translation of the "Original Dokumentation"

AMK

Imprint

Name: PDK_205481_KW26-S5-FSE-4Q

Version:

Version: 2017/02		
Chapter / Topic	Change	Letter symbol
Electrical connections	Assignment motor type DT5	KoJ

Previous version: 2016/31

Product version:

Product AMK part no.	Firmware Version (AMK part no.)	Hardware Version (AMK part no.)
RACING KIT 1 (E1208) RACING KIT 2 (E1209)	Firmware inverter FSE 1.08 2014/47 (205492)	

Copyright notice:

© AMK Arnold Müller GmbH & Co. KG

Any transfer or reproduction of this document, as well as utilisation or communication of its contents, requires express consent. Offenders are liable for the payment of damages. All rights are reserved in the event of the grant of a patent or the registration of a utility model or design.

Reservation:

We reserve the right to modify the content of the documentation as well as the delivery options for the product.

Publisher:

AMK Arnold Müller GmbH & Co. KG

Gaußstraße 37 - 39

D-73230 Kirchheim/Teck

Germany

Phone: +49 7021/50 05-0

Fax: +49 7021/50 05-176

E-mail: info@amk-group.com

Personally liable shareholder: AMK Verwaltungsgesellschaft mbH, Kirchheim/Teck

Registration court: Stuttgart HRB 231283; HRA 230681

Tax-Idnr.: DE 145912804

Service:

Phone: +49 7021/50 05-190, Fax -193

For fast and reliable troubleshooting, you can help us by informing our Customer Service about the following:

- Type plate data for each unit
- Software version
- Device configuration and application
- Type of fault/problem and suspected cause
- Diagnostic messages (error messages)

E-mail: service@amk-antriebe.de

Internet address:

www.amk-group.com

Content

Imprint	2
1 About this documentation	6
1.1 Structure of this document	6
1.2 Keeping this document	6
1.3 Target group	6
1.4 Purpose	7
1.5 Appendant documents	7
1.6 Display conventions	7
2 For your safety	9
2.1 Intended use	9
2.2 Basic notes	9
2.3 Safety rules for handling electrical systems	9
2.4 Presenting safety messages	9
2.5 Class of hazard	10
2.6 Requirements for the personnel and their qualification	10
2.7 Warranty	10
3 Product overview	11
3.1 Product name and ordering data	11
3.2 Product description	11
3.2.1 Inverter overview	11
3.2.2 Servo motor overview	11
3.2.3 AMK AIPEX PRO software	12
3.2.4 AMK RACING KIT product training	12
3.2.5 Defined level of support	12
3.3 Product view – inverter	12
3.4 Product view – motor	14
3.5 System overview (diagram)	14
4 Technical data	15
4.1 Technical data – inverter	15
4.2 Technical data – motor	16
5 Dimensional drawings	17
5.1 Dimensional drawings - Inverter	17
5.1.1 Top view	17
5.1.2 Side view	17
5.2 Dimensional drawings - Motor	18
5.2.1 Side view	18
5.2.2 Front and rear view	18
6 Project planning	19
6.1 Mechanics	19
6.1.1 Mounting options – motor	20
6.1.2 Spline – overview	21
6.1.3 Spline (dimensional drawing)	21
6.2 Liquid cooling	22
6.2.1 Drive system cooling circuit	22
6.2.2 Liquid cooling	23
6.2.3 Liquid cooling – inverter	24
6.2.4 Coolant	26
6.2.5 Cooling circuit	26
6.2.6 Measures to protect the cooling circuit	26
6.2.7 Dew point table	27
6.3 Electric	29

6.3.1 Charging and discharging the HV circuit capacitors	29
6.3.1.1 Calculation example – charging circuit	29
6.3.1.2 Calculation example – discharging circuit	30
6.3.2 PE ground connection – overview	32
6.3.2.1 GND and PE connection – power supply and logic board	33
6.4 Configuration	33
6.4.1 Motor parameters	34
6.4.2 CAN bus communication parameters	34
6.4.3 FSE parameters	35
6.4.4 Default parameters	36
6.4.5 Direction of rotation for motor shaft	37
6.5 Synchronous servo motor with and without field weakening	38
6.5.1 Synchronous servo motor without field weakening	38
6.5.2 Synchronous servo motor with field weakening	38
6.5.3 Characteristics of motor power and motor torque	39
6.5.4 Torque setpoint in field weakening	40
7 Electrical connections	41
7.1 Interface overview and connections – inverter	41
7.1.1 Stranded wires – CAN	43
7.1.2 Stranded wires – HV+ and HV-	43
7.1.3 Stranded wires – motor temperature sensor	44
7.1.4 Stranded wires – motor phases U, V, W	44
7.1.5 [X08] / [X09] 24 VDC supply voltage (on-board supply) and looping	45
7.1.6 [X12] motor thermistor for temperature monitoring	47
7.1.7 [X15] output stage enable (2-channel)	48
7.1.8 [X85] real-time Ethernet (EtherCAT)	49
7.1.9 [X131] motor encoder	50
7.1.10 [X140] binary inputs and outputs	51
7.1.11 [X235] USB	53
7.2 Interface overview and connections – motor	54
7.2.1 M12 motor connector (encoder signals and temperature monitoring)	54
7.2.2 Motor cable	55
7.2.3 PE connection	56
8 Functionality	58
8.1 CAN bus	58
8.1.1 Wiring for two CAN BUS lines	58
8.1.2 Wiring for one CAN BUS line	58
8.1.3 Data telegrams	60
8.1.4 Diagnostic message 3586 (CAN error)	62
8.2 FSE firmware functional description	63
8.2.1 Controller structure	63
8.2.2 Driving modes	64
8.2.3 FSE diagnostic message	65
8.2.4 Units	65
8.2.5 Drive behavior in the event of an error	66
8.2.6 Diagram for error scenarios	68
8.2.7 'Remove error' diagram	68
8.2.8 Torque limitation	69
8.2.9 Battery protection	70
8.3 Motor encoders	70
9 Startup	72
9.1 Wiring the motor and supply cables	72
9.2 Wiring the interface and control cables	73
9.3 Startup with AIPEX PRO	73

9.4 On and off diagram	75
9.5 Optimizing the current controller	76
9.6 Tuning the speed controller	76
9.6.1 Theoretical basis	77
9.6.2 AIPEX PRO settings	80
9.6.3 Optimising the speed controller	84
9.7 Error diagnosis with AIPEX PRO	84
10 Certificates	87
Glossary	88
Your opinion is important!	90

1 About this documentation

1.1 Structure of this document

Topic	Chapter	Chapter number
Validity, use, and the purpose of the document	Imprint	-
	About this documentation	1
Safety	For your safety	2
Information for planning and configuration personnel	Product overview	3
	Technical data	4
	Dimensional drawings	5
	Project planning <ul style="list-style-type: none"> • Mechanics • Liquid cooling • Electrics • Configuration 	6
Practical information for startup, operating, or maintenance personnel	Electrical connections	7
	Functionality	8
	Startup <ul style="list-style-type: none"> • Wiring the motor and supply cables • Wiring the interface and control cables • Startup with AIPEX PRO • Optimization 	9
Reference to Certificates e. g. CSA, CE or TÜV	Certificates	10
Explanations of abbreviations and terms	Glossary	-

1.2 Keeping this document

This document must permanently be available and readable at the place where the product is in use. If the product is used at another place or changed the owner, the document must be passed on.

1.3 Target group

Any person who is entitled and intends to carry out one of the following works must read, understand, and observe this document.

- Transportation and storage
- Unpacking and installation
- Projecting
- Connection
- Parameterization
- Startup
- Testing and maintenance
- Decommissioning and disposal
- Replacement

1.4 Purpose

This document is addressed to any person who handles the product. It gives information about the following topics:

- Safety messages which are absolutely necessary to take care of during handling the product
- Product identification
- Projecting, planning and dimensioning of the application
- Environmental conditions for storage, transportation and operation
- Assembly
- Electrical connections
- Startup and operation
- Maintenance
- Replacement
- Diagnosis
- Technical data

1.5 Appendant documents



The related documents describe products in industrial use. However, they can generally also be used for the AMK RACING KIT.

The main differences are described in this documentation.

Device descriptions

AMK part no.	Title
202276	Motors DD / DT / DTG / DTK / DP
27859	Motor encoders
204260	Motor Controller Electronic MCE
	Motor data sheets

Functional descriptions

AMK part no.	Title
202234	Software description AIPEX PRO (PC software for startup and parameterization)
203771	Software description ATF - AMK Tool Flasher
203704	Parameter description KW-R06 / -R16 / -R07 / -R17 / -R27
25786	Diagnostic messages

1.6 Display conventions

Display	Meaning
	This symbol points to parts of the text to which particular attention should be paid!
	The red hand symbol indicates the button or menu item to click on. The red hand symbol indicates the option to be selected.
RMB	Click the right mouse button
0x	0x followed by a hexadecimal number, e. g. 0x500A
'Names'	e. g.: Calling up the function 'delete PLC program' Parameter names, e. g.: ID2 'SERCOS cycle time' Variable names, e. g.: The variable 'udAccel' contains the acceleration value. Diagnostic message, e. g.: 1042 'Mains phase fault' Safety parameters, e. g.: Prm67 'SMS safe maximum speed'

Display	Meaning
'Text'	Menu items and buttons in a software or on a controller, e. g.: Click the 'OK' button in the 'Options' menu to call up the 'Delete PLC program' function
→	Task procedure / operating sequence, e. g. 'Start' → 'All programs' → 'Additional' → 'Editor' e. g. 0 → 1 edge
<u>See 'chapter name' on page x</u>	Executable cross-reference in electronic output media
IDxxxx - x	List parameter with element number e. g. ID32798 - 1

2 For your safety

2.1 Intended use

The AMK RACING KIT is intended for installation in a Formula Student Electric Car and may only be operated within the specified limits (characteristic curve on motor data sheet, motor type plate).

To comply with the requirements of intended use, the motors must be connected to the inverter included in the RACING KIT. Connecting the motors directly to the supply network is prohibited and can lead to material damage!

The RACING KIT may only be operated on a race track that been cordoned off, and is not approved for use on public roads.

Use in the following areas is prohibited:

- Potentially explosive environments
- Environments containing oils, acids, gases, vapors, dusts, radiation, etc.
- Environments that do not meet the climatic conditions specified in this documentation

2.2 Basic notes

- At electrical drive systems, hazards are present in principle that can result in death or fatal injuries:
 - Electrical hazard (e. g. electric shock due to touch on electrical connections)
 - Mechanical hazard (e. g. crush, retract due to the rotation of the motor shaft)
 - Thermal hazard (e. g. burns due to touch on hot surfaces)
- These hazards are present while starting up and operating the unit, and also during servicing or maintenance work.
- Safety instructions in the documentation and on the product warn about the hazards.
- Personnel must have read and understood the safety instructions before installing and operating the product. In the documentation about the product the usage warnings pertain to direct hazards and must therefore be followed directly when operating or handling the product by the operator.
- AMK products must be kept in their original order, that means it is not allowed to do a significant constructional change on hardware side and software is not allowed to be decompiled and change the source code.
- Damaged or faulty products are not allowed to be integrated or put into operation.
- Do not start the system in which the AMK products are installed (begin of intended use) until you can determine that all relevant standards, laws, and directives have been complied with, e. g. low voltage directive, EMC directive, and the machinery directive, and possible further product standards. The plant manufacturer is responsible for the compliance with the laws, directives, and standards.
- The devices must be installed, electrically connected and operated as shown in the device description documentation. The technical data and the required environmental conditions must be observed at all times.

2.3 Safety rules for handling electrical systems

In particular on drive systems, the instructions pertaining to safety and the following five safety rules have to be kept in the specified sequence:

1. Switch off electrical circuits (also electronic and auxiliary circuits).
2. Secure against being switched on again.
3. Determine that there is no voltage.
4. Earth and short circuit.
5. Cover or close off neighbouring parts that are under voltage.

Reverse the measures taken in reverse order after completing the work.

2.4 Presenting safety messages





Any safety information is configured as follows:

 **SIGNAL WORD**

 Symbol	<p>Type and source of risk Consequence(s) of non-observance</p> <p>Steps to prevent:</p> <ul style="list-style-type: none"> • ...
---	---

2.5 Class of hazard

Safety and warning messages are graduated into classes of hazard (according to ANSI Z535). The class of hazard defines the risk if the safety message is not heeded and is defined by the signal word. The signal word is followed by a safety alert symbol (ISO 3864, DIN EN ISO 7010). In accordance with ANSI Z535, the following signal words are used to define the class of hazard.

Safety alert symbol and signal word	Class of hazard and its meaning
	DANGER indicates a hazardous situation which, if not avoided, will result in death or serious injury
	WARNING indicates a hazardous situation which, if not avoided, could result in death or serious injury
	CAUTION, used with the safety alert symbol, indicates a hazardous situation which, if not avoided, could result in minor or moderate injury
	NOTICE is used to address preventions to avoid material damage, but not related to personal injury.

2.6 Requirements for the personnel and their qualification

Only authorized and qualified personnel may work on and with the AMK drive systems.

Specialised personnel must:

- Perform mechanical and electrical work that is described in this documentation, such as mounting and connecting
- Observe all information in the documentation accompanying the product in order to work with the product safely and in an error-free manner
- Understand and know hazards that occur when handling the product
- Know connections and functions of the system
- Be familiar with the control concept in order to operate the drive system
- Be authorized to switch circuits and devices on and off, earth and label them
- Observe local specific safety requirements

2.7 Warranty

- All information in the documents accompanying the product must be complied with for a safe and trouble-free operation.
- The assertion of warranty claims is excluded if the information in the documents is not observed completely.
- Hardware and firmware may not be modified except by personnel authorised by AMK and after consultation with AMK.
- The company AMK Arnold Müller GmbH & Co. KG is not liable for damages from unintended use, incorrect installation or operation, exceeding rated values and non-observance with the environmental conditions.

3 Product overview

3.1 Product name and ordering data

Product name	Order number
AMK RACING KIT 1 ¹⁾	E1208
AMK RACING KIT 2 ²⁾	E1209

The AMK RACING KIT consists of the following components:

Product name	Quantity	Order number
¹⁾ DYNASYN synchronous servo motor DD5-14-10-POW-18600-B5	4	A2370DD
²⁾ DYNASYN synchronous servo motor DT5-14-10-POW-14000-B5	4	A2371ED
AMKASYN inverter KW26-S5-FSE-4Q	1	47541
AMK AIPEX PRO V3 startup software	1	O907
USB cable with ferrite, 3 m	1	47058
AMK RACING KIT product training	1	N308
FSE doc. CD	1	tbd
Defined level of support	1	N307

3.2 Product description

The AMK RACING KIT consists of a quad inverter with integrated drive controllers and 4 synchronous servo motors. For startup, the kit contains the AMK AIPEX PRO V3 software and a USB cable.

The torque at the servo motor is controlled subject to the setpoint (accelerator position). The setpoint for the inverters is specified via a higher-level CAN controller. The inverters operate the servo motors in the speed control operating mode. In contrast to the torque control operating mode, the advantage of this mode is that the motor speed can be limited dynamically in addition to the limitation of the torque.

The inverters are operated with the AMK 'Formula Student Electric' firmware. 'Formula Student Electric' is subsequently abbreviated in the documentation to 'FSE'.

Communication between the inverters and the higher-level controller takes place via a CAN bus 2.0 B. Clearly defined CAN messages are implemented for exchanging information.

The servo motors can be driven by a motor and a generator (recuperative).

3.2.1 Inverter overview

- Field-based regulation of permanent-magnet synchronous servo motors
- Speed control with torque limitation for motor and recuperative operation
- Temperature monitoring of the motor and inverter
- Torque limitation in the event of overload and excess temperature
- Torque limitation in the event of undervoltage or overvoltage in the HV circuit
- CAN bus 2.0 B interface as per ISO 11898
- I/O interface (motor control and motor torque hardware release)
- EtherCAT (SoE), USB (AMK AIPEX PRO software) service interface
- Mounted on liquid-cooled cold plate

3.2.2 Servo motor overview

- Permanent-magnet synchronous servo motors
- $M_{max}/M_N = 2.1$
- Field-weakening operation possible, speeds up to 20,000 rpm
- Digital EnDat encoder (AMK classification P)
- KTY temperature sensor
- Shielded power cable
- M12 plug for encoder signals and temperature monitoring

- Motor casing made from aluminum 3.4365/EN AW-7075
- Shaft with spline as per DIN 5480
- Rear or front mounting
- Liquid cooling system must be constructed by the user

3.2.3 AMK AIPEX PRO software

- Configuration
- Startup, optimization (test generator and oscilloscope)
- Diagnosis
- Interface to inverter: EtherCAT or USB

3.2.4 AMK RACING KIT product training

A 2-day training course for 2 participants at AMK in Kirchheim/Teck, Germany, is included in the price of the package.

Training content:

- Device overview
- Connection technology
- CAN interface
- Working with the AMK AIPEX PRO startup software
- Configuration and startup
- Question and answer session with AMK employees from the power electronics and motor engineering development departments

Accommodation and travel costs are to be borne by you.

3.2.5 Defined level of support

10 hours of phone and/or e-mail support from AMK is included in the price of the package.

3.3 Product view – inverter

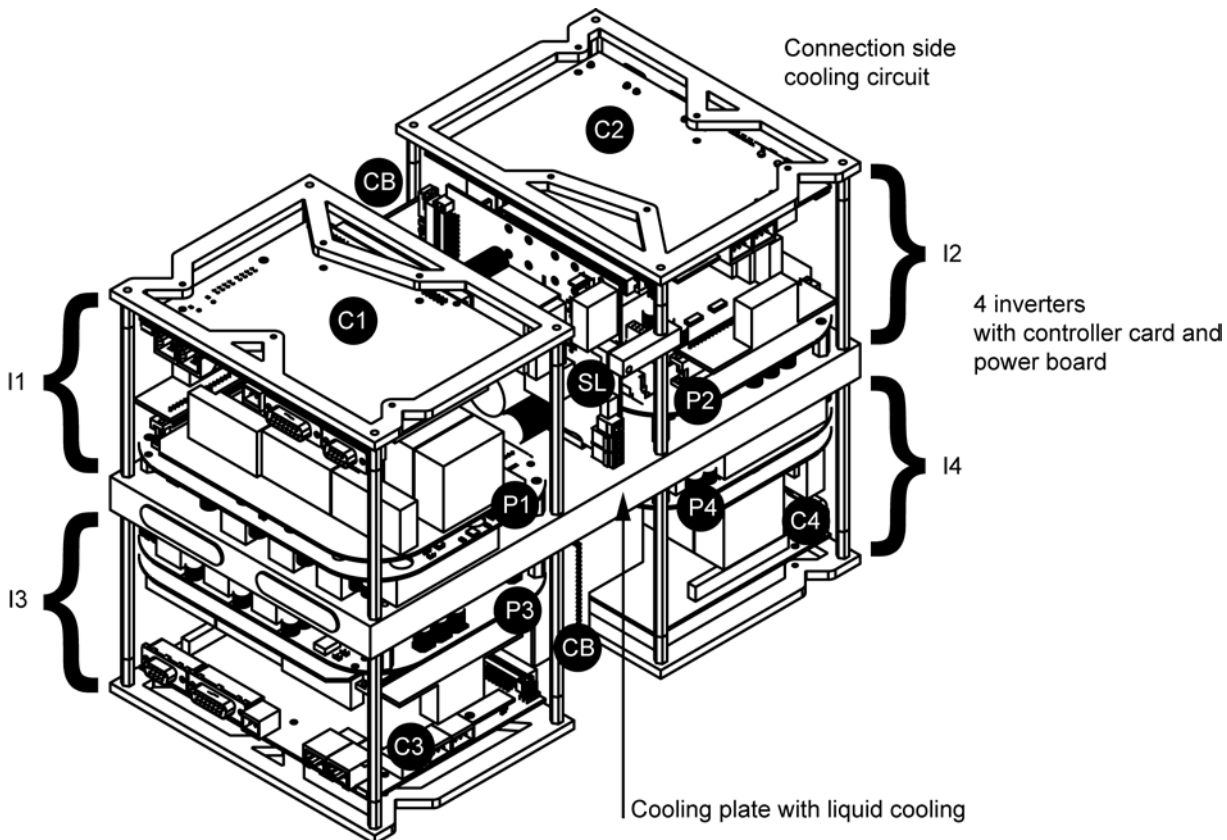

With respect to the illustrations shown in the documentation, please pay attention to the label 'Cooling circuit connection side'.

- I1 - Inverter (contains power electronics and a controller card for a motor)
- P1 - Power electronics for inverter I1
- C1 - Controller card for inverter I1
- SL - Power supply and logic board for I1 and I2, and I3 and I4
- QB - Transverse board, connects I1 with I2, and I3 with I4

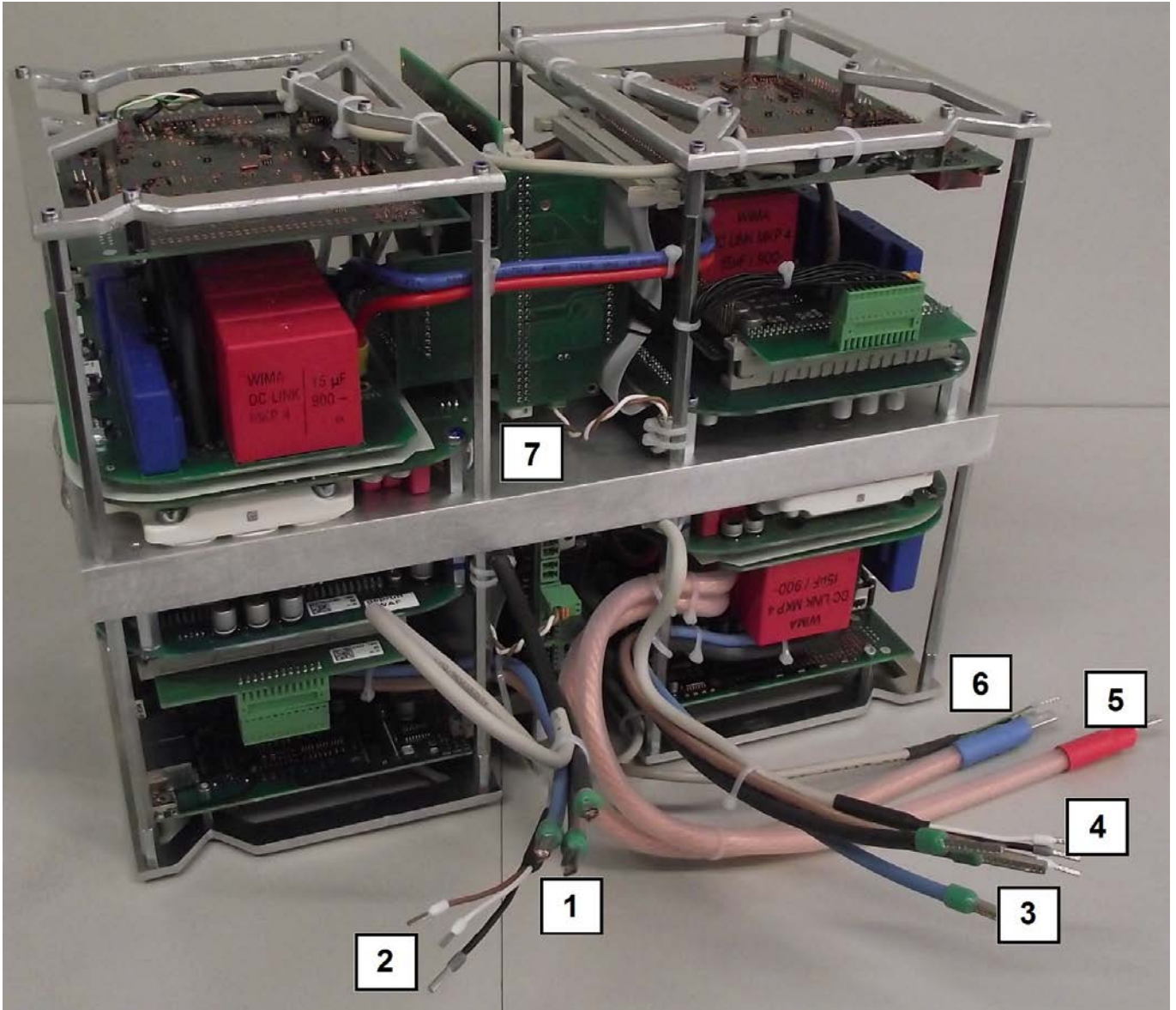

Number	Connection wire
1	Motor W3
2	Motor temperature sensor W3
3	Motor W4
4	Motor temperature sensor W4
5	HV voltage
6	CAN
7	Motor temperature sensor W1

3.4 Product view – motor

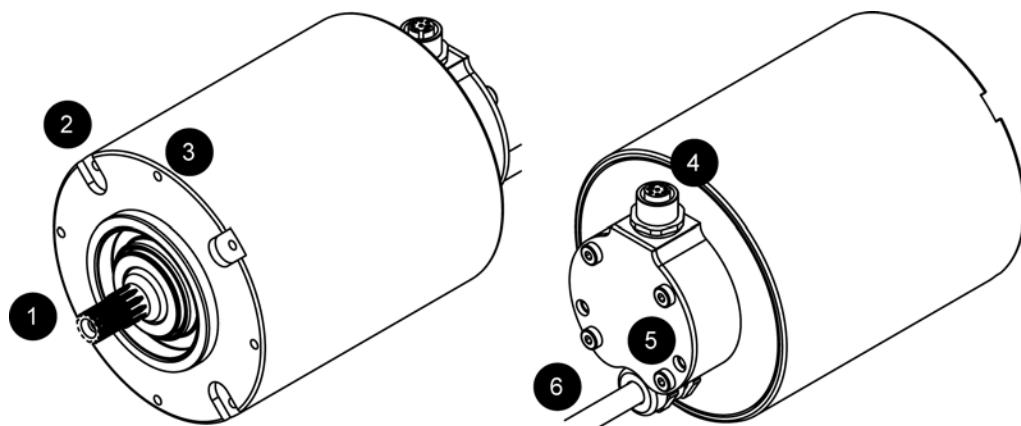

- 1 - Motor shaft with spline
- 2 - Notch for mounting plate
- 3 - Mounting thread
- 4 - Motor connector (encoder signals and temperature sensor)
- 5 - PE connection (2 x)
- 6 Motor cable (phases U, V, W)

3.5 System overview (diagram)

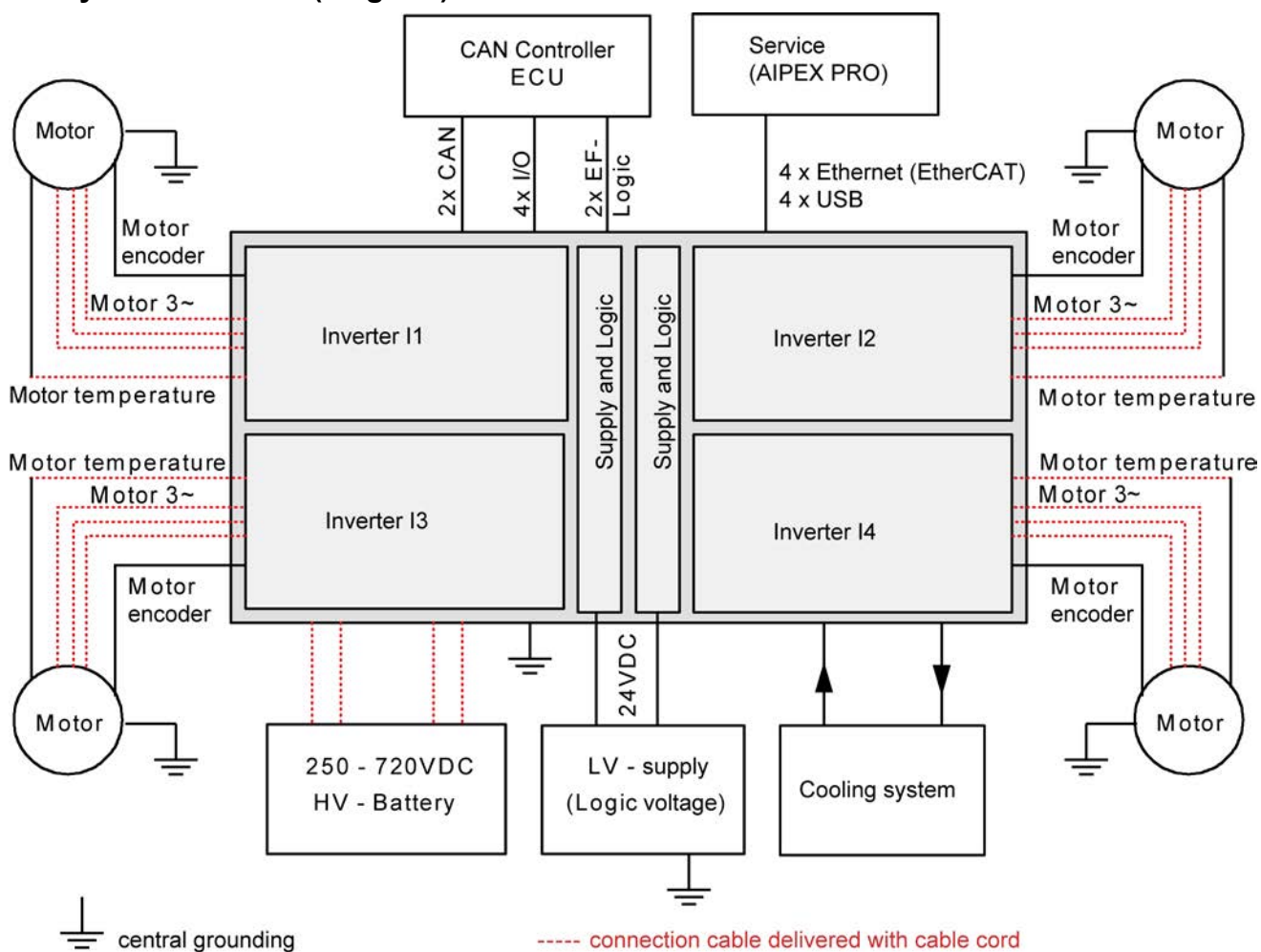

4 Technical data

4.1 Technical data – inverter

	Terminal / strand	KW26-S5-FSE-4Q (data per inverter)	
Rated input voltage HV+, HV- power supply	HV+, HV-	540 VDC	
Input voltage range		250 VDC - 720 VDC	
Input current Power supply for HV = 540 VDC		48 A	
Intermediate circuit capacity		75 μ F	
Supply voltage for logic supply LV	X08 (X09)	24 VDC \pm 15%, The 0 V potential must be connected to the vehicle ground (vehicle chassis).	
Input current for logic supply LV		\leq 500 mA	
Capacity at input of internal switched-mode power supply		1,500 μ F	
Efficiency		Approx. 98%	
Ground		Vehicle ground (vehicle chassis) or ground strap Switching GND for logic voltage is internally connected to the frame of the inverter	
Control method Switching frequency		PWM 8 kHz	
Output frequency ¹⁾	U, V, W	0 - 1200 Hz	
Output voltage (HV = 540 VDC)		350 VAC (sinusoidal output current)	
Output voltage range (HV = 250 - 720 VDC)		160 - 490 VAC	
Rated output power		26 KVA	
Rated output current I_N		43 A	
Peak output current I_{max}		105 A	
Max. duration of peak output current I_{max}			
Output frequency $f_{OUT} > 1$ Hz		10 s	
Output frequency $f_{OUT} \leq 1$ Hz		1 s	
Temperature sensor evaluation		X12	KTY e.g., KTY84-130
Protective / monitoring function		Short-circuit / ground fault, intermediate circuit overvoltage, excess temperature at motor / heat sink, current overload as per I ² t	
Cooling	Liquid cooling		
Flow rate	1.5 bar / 10 l/min		
Max. cold plate and ambient temperature	40 °C		
Protection class	IP00		

	Terminal / strand	KW26-S5-FSE-4Q (data per inverter)
Dimensions (quad inverter)	241 x 339 x 183 mm	
Weight for quad inverter including heat sink	Approx. 11 kg	

1) Speed setpoint values are limited to 30000 rpm

4.2 Technical data – motor

Please refer to the motor data sheet for the technical data for the motor.



When the system is started up for the first time, the motor parameters are automatically transferred from the encoder database to the inverter.

The function is not performed if the motor parameters have already been entered manually. The AIPEX PRO's 'Initial program loading' function in direct mode allows the factory settings from AMK to be restored.

Prerequisite for the automatic transfer of the data from the encoder database:

- Encoder cable connected
- Motor parameters have not already been changed manually
- The data has been stored in the encoder at the factory

5 Dimensional drawings

5.1 Dimensional drawings - Inverter

5.1.1 Top view

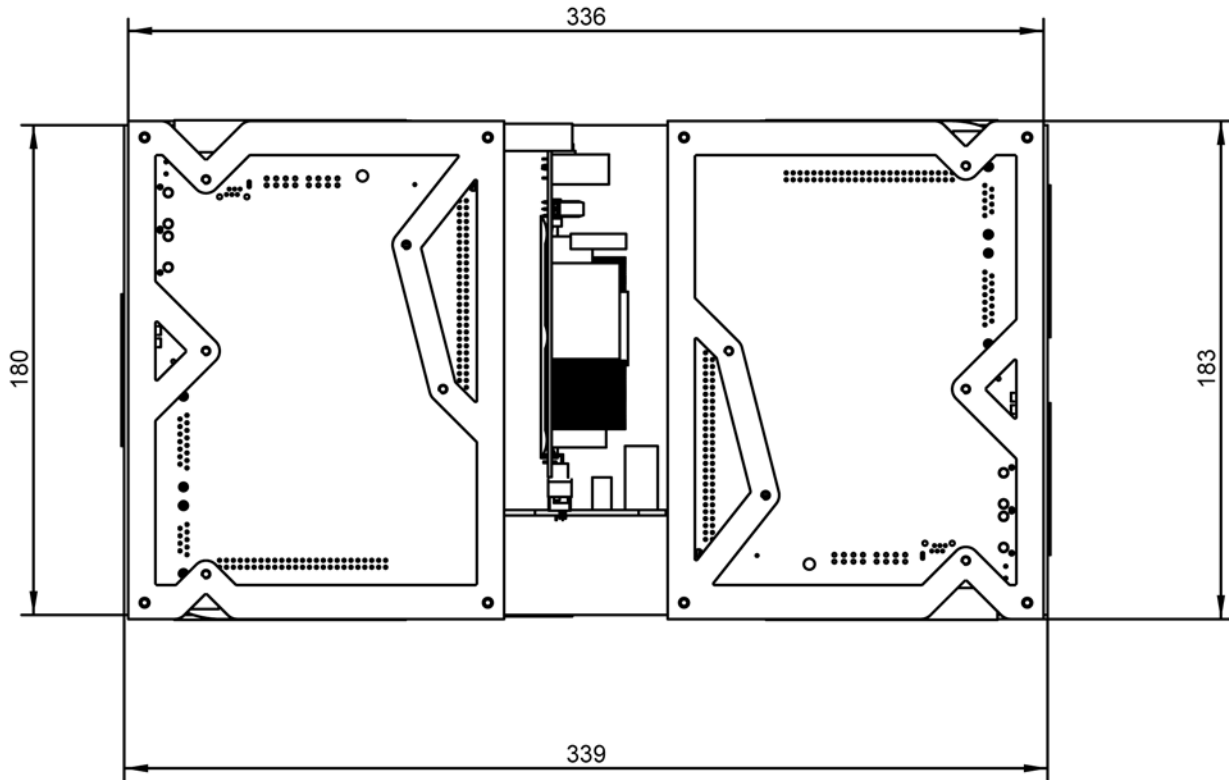

5.1.2 Side view

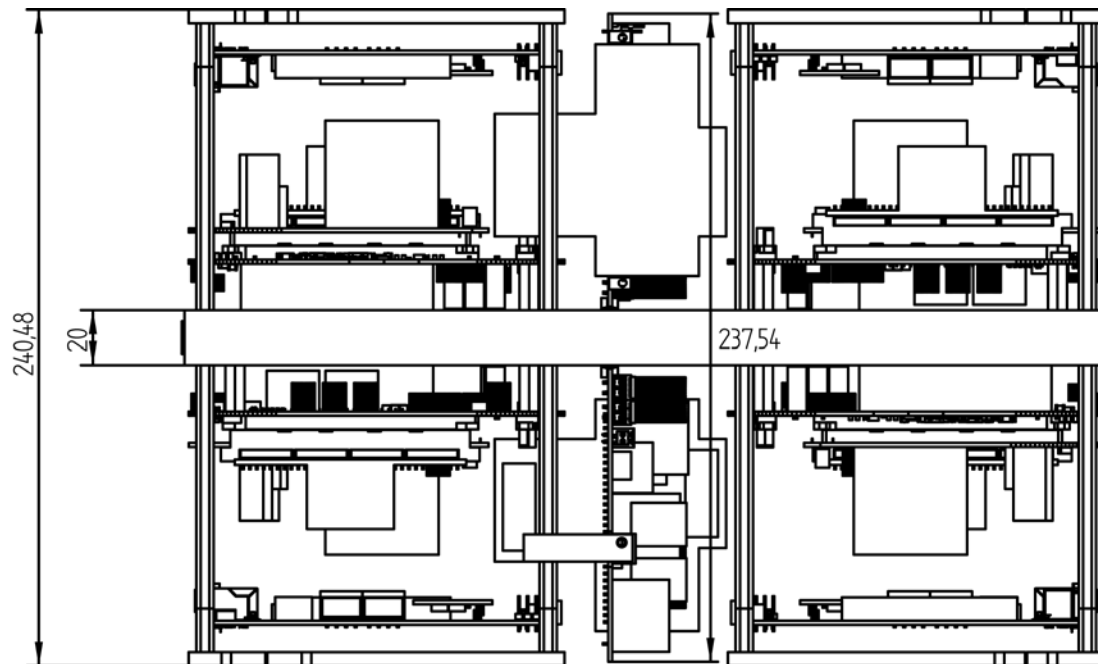

5.2 Dimensional drawings - Motor

5.2.1 Side view

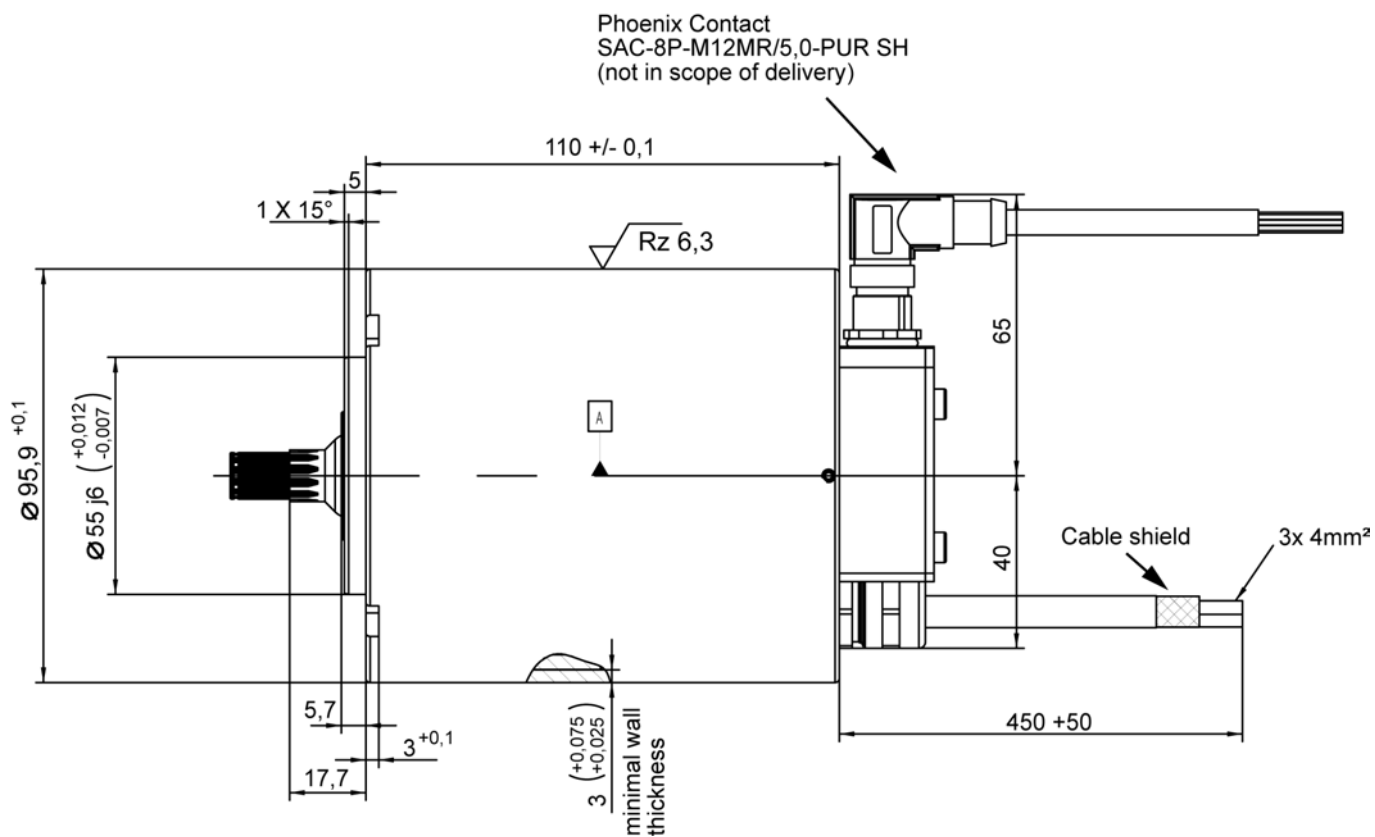

5.2.2 Front and rear view

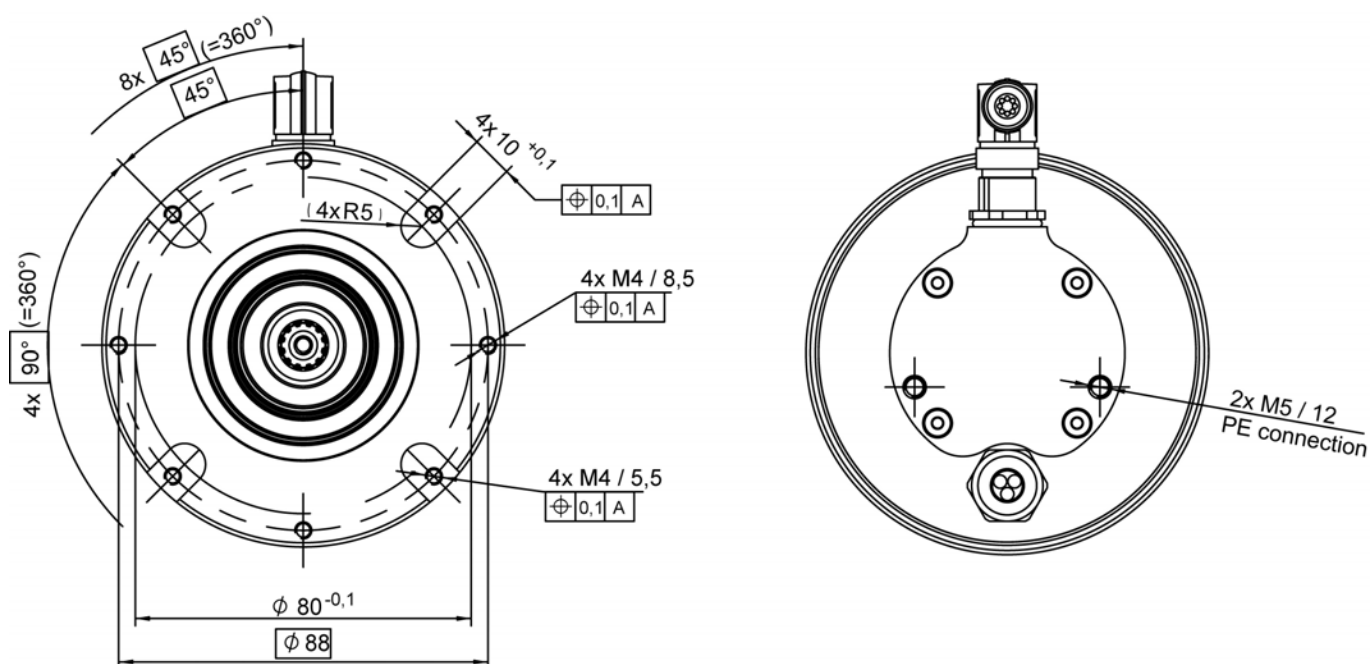

Dimensional drawing of spline: [See 'Spline \(dimensional drawing\)' on page 21.](#)

6 Project planning

6.1 Mechanics

NOTICE	
Material Damage!	<p>Mechanical damage due to pressure on the motor shaft</p> <p>Pressure on the motor shaft can damage the motor bearings or cause the motor shaft to move out of its fixing and into the motor casing.</p> <p>Preventive measures:</p> <p>Mounting parts such as toothed wheels or shafts must be attached without force (not pressed in) and must then be secured with a screw or a retaining ring.</p>

NOTICE	
Material Damage!	<p>Mechanical damage due to pressure on the B-bearing shield</p> <p>By pressing on the B-bearing shield the housing screws may break. The motor housing is damaged and the B-bearing shield is moving into the motor housing.</p> <p>Preventive measures:</p> <p>Support mechanically the motor housing (picture pos. 1 + 2) so that during assembly of attachments e. g. the external liquid cooling no pressure on the B-bearing shield is applied.</p> <div style="text-align: right;">  </div>

6.1.1 Mounting options – motor

The motor can be mounted either at the rear via the 8 x M4 threads or at the front.

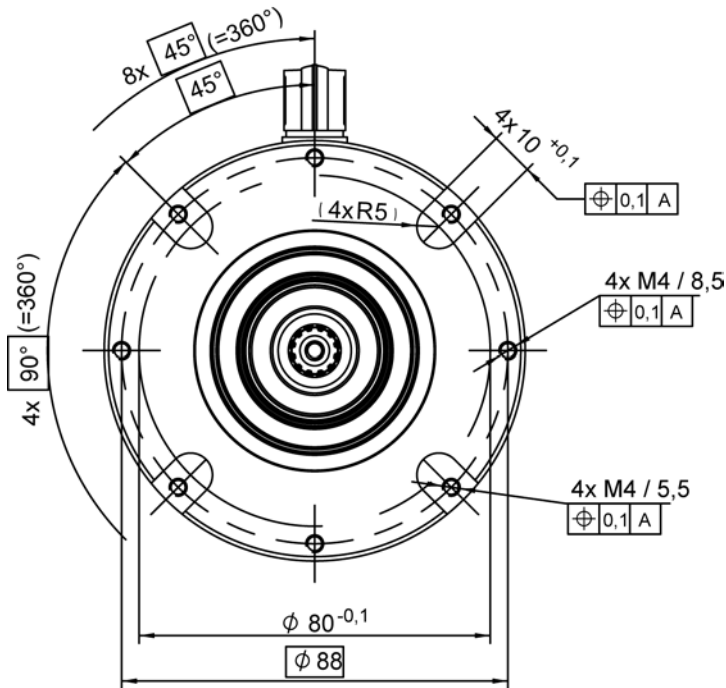

Front mounting

The mounting plates indicated in the drawing are required for front mounting. The mounting plates are not included in the scope of delivery and must be provided by the user.

The mounting plates can be fastened in the front end of the motor at the 4 x 10 mm wide notches.

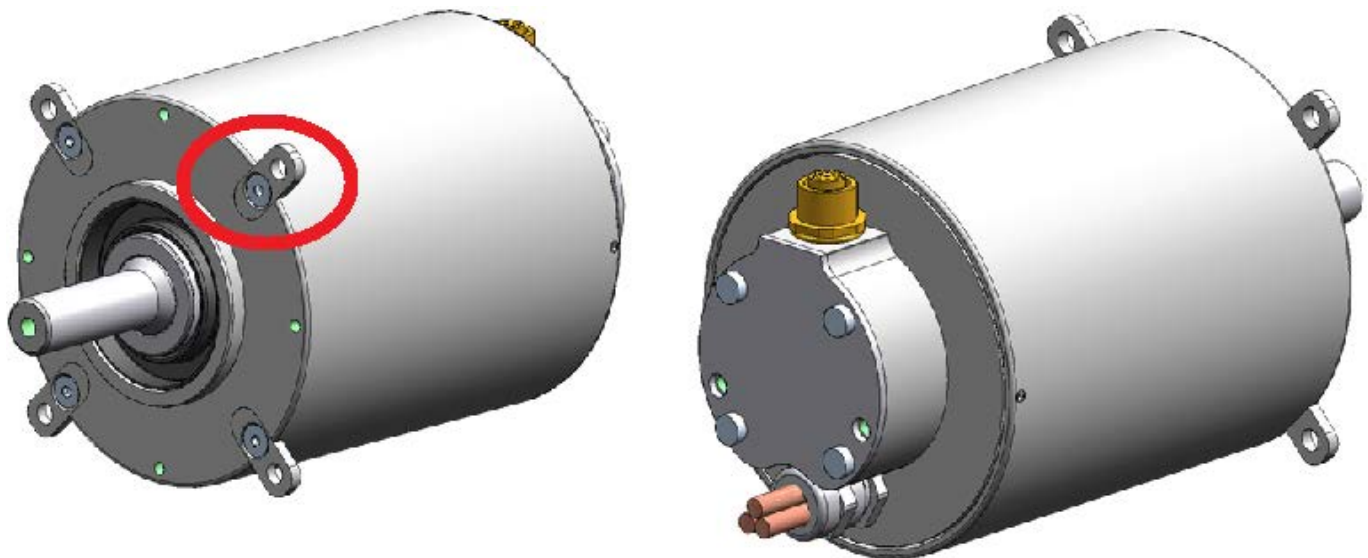

Rear mounting

Fixation via 8 x M4 threads.

6.1.2 Spline – overview

NOTICE	
Material Damage!	<p>Mechanical damage due to pressure on the motor shaft</p> <p>Pressure on the motor shaft can damage the motor bearings or cause the motor shaft to move out of its fixing and into the motor casing.</p> <p>Preventive measures:</p> <p>Mounting parts such as toothed wheels or shafts must be attached without force (not pressed in) and must then be secured with a screw or a retaining ring.</p>

The motor shaft contains a spline in accordance with DIN 5480 – W11 x 0.8 x 30° x 12 x 7h

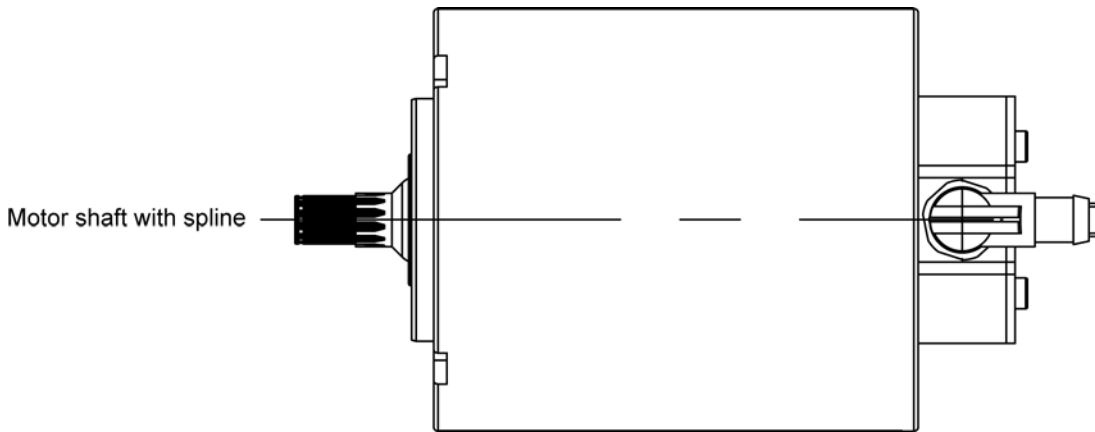

6.1.3 Spline (dimensional drawing)

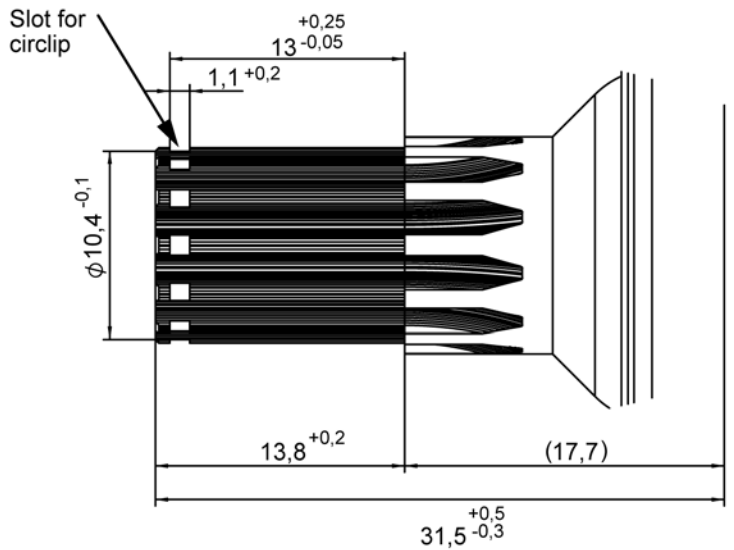

Spline on Shaft: DIN 5480 - W11x0,8x30°x12x7h

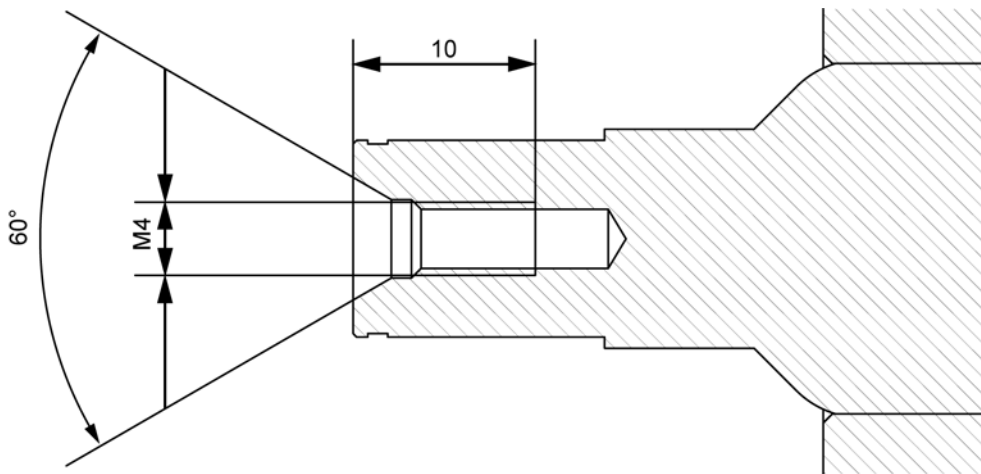

6.2 Liquid cooling

6.2.1 Drive system cooling circuit

NOTICE

Material Damage!	<p>Material damage due to overheating!</p> <p>The drive system is intended solely for operation in a closed cooling circuit with a heat exchanger. Operation without the specified cooling system is not permitted. The drive system will overheat, causing it to be destroyed.</p>
	<p>Preventive measures:</p> <ul style="list-style-type: none"> • Only operate the drive system with the specified cooling system • Connect the PTC thermistor from the servo motor to the temperature monitoring equipment • Activate the I²t monitoring of the servo motor in ID32773 'Service bits', bit 14

⚠ WARNING

	<p>Warning against pressurised lines!</p> <p>Closed cooling circuits are under high pressure. Opening the circuit while it is under high pressure can result in injuries from escaping coolant. The sudden pressure change can cause lines to rip loose or make uncontrolled movements.</p>
	<p>Steps to prevent:</p> <ul style="list-style-type: none"> • Never open a line system that is under high pressure! • Drain the coolant at the provided point, e.g. drain valve. Pay attention to the instructions of the manufacturer of the cooling device. • Collect the cooling liquid in a proper containment. Store or dispose it according to the local instructions. • Wear adequate protective clothing, e.g. goggles, gloves, safety shoes.

Inverters:

The inverters are mounted on an aluminum cold plate with liquid cooling. The maximum permissible surface temperature of the cold plate is 40 °C. The cold plate can be connected directly to a cooling circuit.

Boundary conditions for the inverter cold plate:

- The maximum permissible surface temperature of the cold plate is 40 °C
- The flow rate must be approx. 10 l/min
- The coolant must be < 30 °C at the inlet

Motors:

The thermal losses incurred in the motor are generated from power loss P_V , which must be dissipated. The cooling jacket for the motor must be designed and constructed by the user.

Boundary conditions for the motor:

- The coolant temperature must not exceed the maximum permissible inlet temperature of 40 °C
- The minimum flow rate must be 2 l/min
- The maximum temperature increase of the coolant must be < 5 K



The coolant temperature must be adapted to the environment in accordance with the dew point table. Condensation must not be allowed to form on the motor surface or cold plate.



The requirements regarding the cooling circuit and the quality of the coolant must be observed.

6.2.2 Liquid cooling

Liquid-cooled motors are intended for use in a closed cooling circuit with recirculation unit. Only deionized water has to be used. Additives and lightproof components can be used to prevent algae growth. If there is risk of frost, frost protection measures (anti-freeze agent) are necessary.

For transport and storage, the cooling circuit has to be emptied and purged with air.

Stainless steel or lightproof plastic can be used for the connections and lines. If different materials make contact directly or indirectly, the electrochemical series of the materials has to be observed. Therefore no zinc may be used in the cooling circuit.

Motor cooling area

The liquid cooling system must be constructed by the user.



Operation of the motor without the specified liquid cooling system is not permitted. The motor will overheat, causing it to be destroyed.

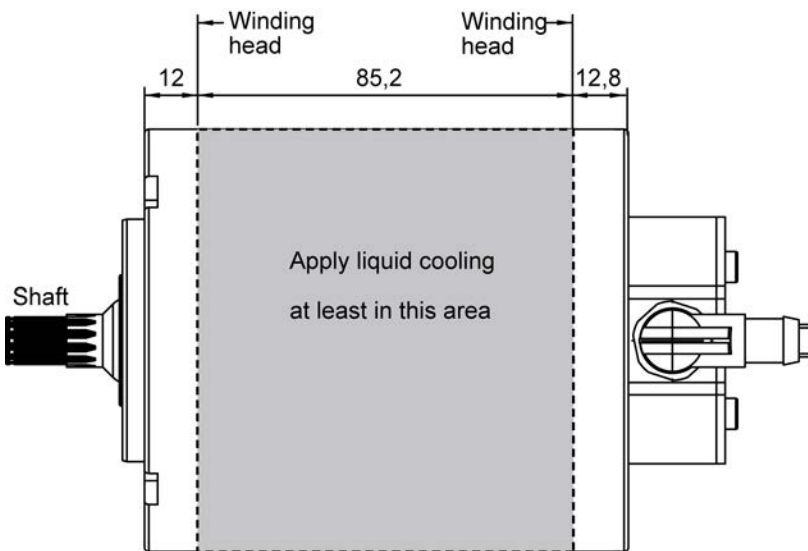

Thermal losses at the motor

The thermal losses P_V are calculated as follows:

$$P_V [W] = M [Nm] \times n [1/min] \times \frac{\pi}{30} \times \left[\frac{1}{\eta} - 1 \right]$$

- M Torque
- n Speed
- η Efficiency



The torque, speed, and efficiency can be obtained from the efficiency curve on the motor data sheet.

In the case of liquid-cooled motors, the power loss that can be dissipated is proportional to the flow rate of the coolant. The minimum coolant flow rate over a period of time is calculated as follows:

$$Q \left[\frac{\text{l}}{\text{min}} \right] = \frac{P_v [\text{W}] \times 60}{\Delta T [^\circ\text{C}] \times C}$$

ΔT : Permissible temperature increase of the coolant between flow and return $\Delta T < 5 \text{ }^\circ\text{K}$

C: Specific thermal capacity of the coolant, e.g., water: 4187 J/(kg·K)

6.2.3 Liquid cooling – inverter

The liquid-cooled cold plate is used to dissipate the power loss from the power electronics of the inverters.

The cold plate consists of a heat sink made from an AlMgSi 0.5 aluminum alloy with an integrated cooling channel. The heat is dissipated via the water that is routed through the cold plate.



The power loss from the control electronics is not dissipated via the cold plate. The heat that arises has to be extracted separately.

Technical data for the FSE cold plate:

Maximum power that can be dissipated ¹⁾	2,000 watts
Water flow	1.5 bar; 10 l/min
Ambient temperature during operation	+5 °C to +40 °C
Relative humidity	5% to 85%, non-condensing
Coolant pipe material	AlMgSi 0.5
Dimensions	339 x 180 mm
Coolant connection	G 1/4" internal thread

1) At 25 °C and 10 l/min

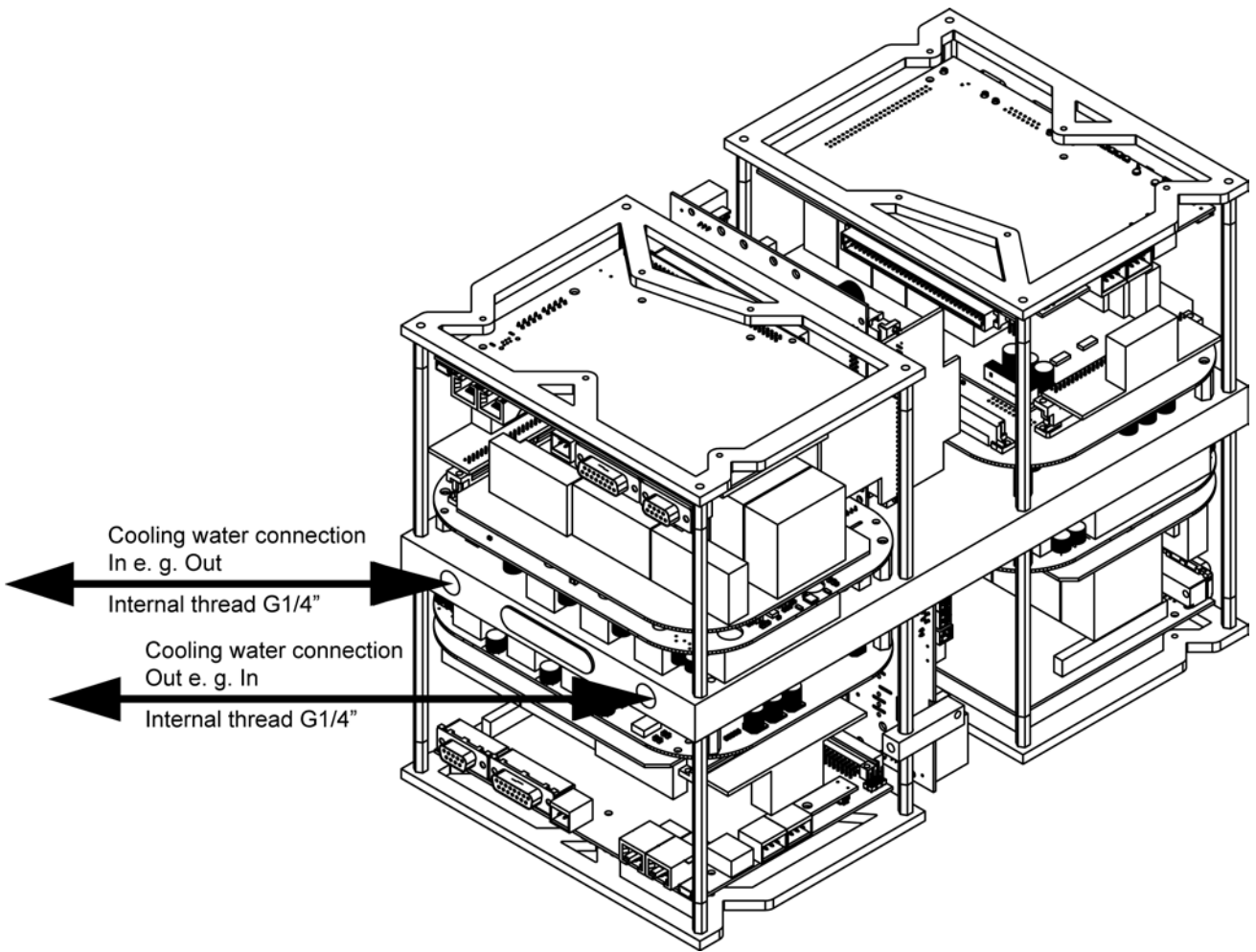

The illustration shows the cooling channel in the cold plate.

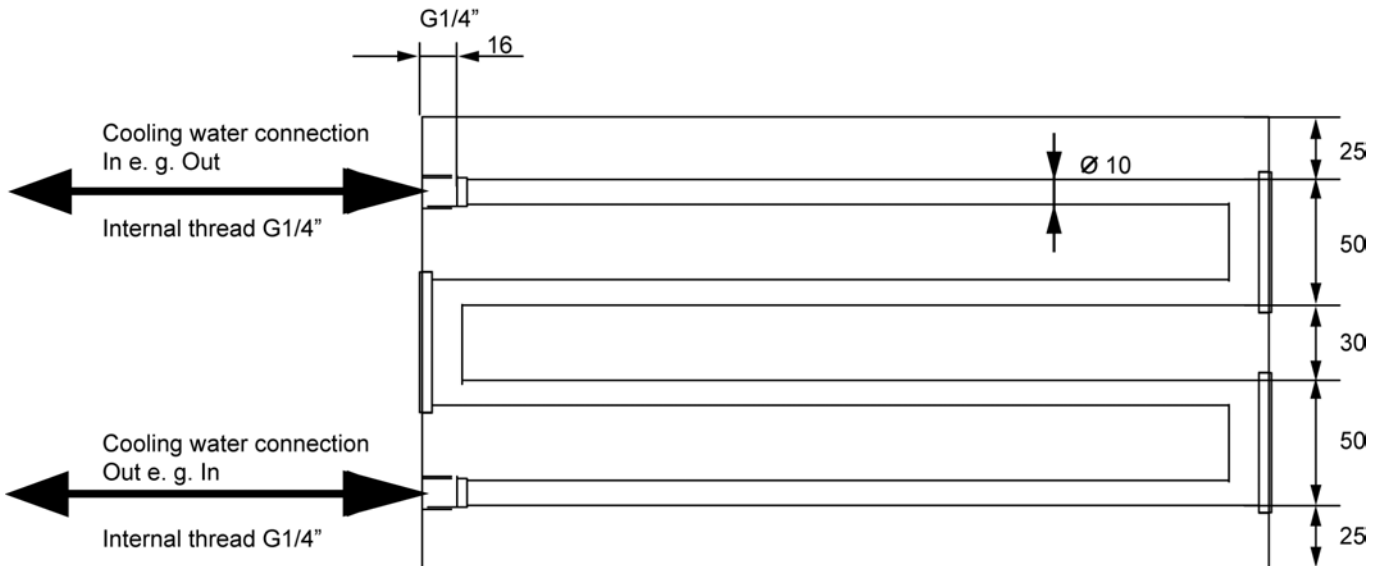

Installing the cooling circuit

The coolant is connected from the side using two G 1/4" internal threads and the corresponding hose fittings.
 Tightening torque for G 1/4": max. 20 Nm

6.2.4 Coolant

Requirements to the quality of the water used as coolant

Components	Quantities
Chloride ions	< 40 ppm ¹⁾
Sulphate ions	< 50 ppm
Nitrate ions	< 50 ppm
pH value	6...12
Electrical conductivity	< 500 µS/cm
Total hardness	< 170 ppm

1) 1 mmol/l (alkaline earth ions) = 100 ppm (part per million)

1 °dH = 17.8 ppm

Drinking water can have a chloride ion count of up to 2500 ppm. Add deionised water with reduced conductivity (5...10 µS/cm). Ask your water supplier about the composition of your drinking water.

Requirements to the coolant

Components	Quantities
Frost protection	If necessary: 20-30% Antifrogen N (manufacturer: Clariant) or Tyfocor L (manufacturer: Tyfocorp) ¹⁾
Solutes	< 340 ppm
Size of particles in the coolant	< 100 µm

1) The antifreeze protection quantity has to be < 30 %, else derating is required. Consult the AMK customer service.

6.2.5 Cooling circuit

Requirements for the cooling circuit

NOTICE	
Material Damage!	<p>Damage to the cooling plate due to electrolysis</p> <p>The cooling plate is made of an AlMgSi 0.5 aluminium alloy. If components such as supply line pipes and heat exchangers that are made of more precious materials (e.g. copper) are used within the cooling circuit, they can be affected and damaged due to electrolytic processes.</p> <p>Steps to prevent:</p> <ul style="list-style-type: none"> • Only use components made of the same or a comparable aluminium alloy within the cooling circuit

The installation of a closed cooling circuit with the following properties is recommended:

- No constant addition of freshwater, through this the water quality is controllable and consistent
- Light-proof cooling system in order to hinder the growth of algae
- Negligible loss through evaporation

If there are critical water circumstances, an expert institute should be contacted for a water analysis.

6.2.6 Measures to protect the cooling circuit

In cooling circuits with water, measures must be taken through additives¹⁾ against the following topics:

1) The dosing and further data about the water quality can be found in the product specifications from the supplier of the inhibitor. In general, the guidelines from the heat exchanger manufacturer apply.

Corrosion

A corrosion protection for the complete cooling circuit must be guaranteed with the usage of mixed material.

The material may vary according to the arrangement (aluminium, steel, copper, brass, plastic, ...) and according to its composition of the selected cooling components (observe manufacturer's guideline).

When using aluminium in the cooling circuit, it must be guaranteed that there is no direct contact of the aluminium with the copper parts. In order to avoid selective corrosion, the possible copper decontamination must be removed carefully through customer handling or through miscellaneous modifications (for example, by flushing out the cooling canal).

Scale formation

In order to avoid to formation of scale, for example, the hardness of the water should be limited or the use of hardness stabilizers may make sense.

Algae growth

In closed systems without the addition of oxygen or with light-proof installations not critical, otherwise it must be worked with suitable biocides.

Biological attack, formation of mucus bacteria

An attack, or the constant addition of materials promoting the growth of bacteria must be avoided.

Frost

If there are possible temperatures below the freezing point (transport, storage....), measures against frost damage must be taken.

Environment tolerability

The environment tolerability of the protective material used must received special value.

6.2.7 Dew point table

NOTICE	
Material Damage!	<p>Material damage when dew forms! Dew may result in electrical shorts.</p> <p>Steps to prevent:</p> <ul style="list-style-type: none"> • Observe the dew point table! • Switch off the cooling circuit when the systems are idle! • Check the temperature of the coolant after longer downtimes! • At high levels of humidity, it is recommended to use a dehumidifier!

The dew point table specifies at which surface temperature condensate forms. This depends on the temperature of the air and the relative humidity.

Example: Ambient temperature: 32 °C, humidity: 60 %
The temperature of the cooling circuit may not be less than 23 °C, else condensate will form!

Ambient air temperature in °C	Dew point in °C at a relative humidity of										
	45%	50%	55%	60%	65%	70%	75%	80%	85%	90%	95%
2	-7,70	-6,26	-5,43	-4,40	-3,16	-2,48	-1,77	-0,98	-0,26	0,47	1,20
4	-6,11	-4,88	-3,69	-2,61	-1,79	-0,88	-0,09	0,78	1,62	2,44	3,20
6	-4,49	-3,07	-2,10	-1,05	-0,08	0,85	1,86	2,72	3,62	4,48	5,38
8	-2,69	-1,61	-0,44	0,67	1,80	2,83	3,82	4,77	5,66	6,48	7,32
10	-1,26	0,02	1,31	2,53	3,74	4,79	5,82	6,79	7,65	8,45	9,31
12	0,35	1,84	3,19	4,46	5,63	6,74	7,75	8,69	9,60	10,48	11,33
14	2,20	3,76	5,10	6,40	7,58	8,67	9,70	10,71	11,64	12,55	13,36
15	3,12	4,65	6,07	7,36	8,52	9,63	10,70	11,69	12,62	13,52	14,42
16	4,07	5,59	9,98	8,29	9,47	10,61	11,68	12,66	13,63	14,58	15,54
17	5,00	6,48	7,62	9,18	10,39	11,48	12,54	13,57	14,50	15,36	16,19
18	5,90	7,43	8,83	10,12	11,33	12,44	13,48	14,56	15,41	16,31	17,25
19	6,80	8,33	9,75	11,09	12,26	13,37	14,49	15,47	16,40	17,37	18,22
20	7,73	9,30	10,72	12,00	13,22	14,40	15,48	16,46	17,44	18,36	19,18
21	8,60	10,22	11,59	12,92	14,21	15,36	16,40	17,44	18,41	19,27	20,19
22	9,54	11,16	12,52	13,89	15,19	16,27	17,41	18,42	19,39	20,28	21,22
23	10,44	12,02	13,47	14,87	16,04	17,29	18,37	19,37	20,37	21,34	22,23
24	11,34	12,93	14,44	15,73	17,06	18,21	19,22	20,33	21,37	22,32	23,18
25	12,20	13,83	15,37	16,69	17,99	19,11	20,24	21,35	22,27	23,30	24,22
26	13,15	14,84	16,26	17,67	18,90	20,09	21,29	22,32	23,32	24,31	25,16
27	14,08	15,68	17,24	18,57	19,83	21,11	22,23	23,31	24,32	25,22	26,10
28	14,96	16,61	18,14	19,38	20,86	22,07	23,18	24,28	25,25	26,20	27,18
29	15,85	15,58	19,04	20,48	21,83	22,97	24,20	25,23	26,21	27,26	28,18
30	16,79	18,44	19,96	21,44	23,71	23,94	25,11	26,10	27,21	28,19	29,09
32	18,62	20,28	21,90	23,26	24,65	25,79	27,08	28,24	29,23	30,16	31,17
34	20,42	22,19	23,77	25,19	26,54	27,85	28,94	30,09	31,19	32,13	33,11
36	22,23	24,08	25,50	27,00	28,41	29,65	30,88	31,97	33,05	34,23	35,06
38	23,97	25,74	27,44	28,87	30,31	31,62	32,78	33,96	35,01	36,05	37,03
40	25,79	27,66	29,22	30,81	32,16	33,48	34,69	35,86,	36,98	38,05	39,11
45	30,29	32,17	33,86	35,38	36,85	38,24	39,54	40,74	41,87	42,91	44,03
50	34,76	36,63	38,46	40,09	41,58	42,99	44,33	45,55	46,75	47,90	48,98

The use of a dehumidifier in the switch cabinet is recommended in case of high levels of humidity.



6.3 Electric

6.3.1 Charging and discharging the HV circuit capacitors

The HV circuit capacitors in the inverters must be charged and discharged via an external charging device.

The HV circuit capacity is 300 µF in total (75 µF per inverter).

The charging- and discharging device does not part of the RACING KIT and must be designed by the user.

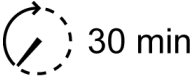
 DANGER	
 	<p>Danger to life from electric shock!</p> <p>After switching off the HV circuit, the buffer capacitors for the DC bus can still have a charge and lead to a life-threatening DC voltage if they are not discharged via an external circuit.</p> <p>Steps to prevent:</p> <ul style="list-style-type: none"> • Prior to all work on the device, the HV power supply is to be separated from the main switch and secured against restarting. • After switching off, expect a discharge time of at least 30 minutes. • Measure the terminal voltage, e.g. in the HV DC bus between the HV+ and HV- terminals to ensure that the terminal is voltage-free. • Caution: A voltage-free state is not signalled! • Use external discharge circuit. See 'Calculation example – discharging circuit' on page 30.

6.3.1.1 Calculation example – charging circuit

5 capacitors (each 15 µF) are connected in parallel for each inverter.

Maximum pulse peak per capacitor: 240 A

Effective current per capacitor (at 10 kHz): 10.5 A

Calculation example:

$U_o = 500 \text{ V}$	$U_o = \text{HV battery voltage (DC circuit voltage)}$
$t = 0.2 \text{ s}$	$t = \text{Charging time via charging resistor (predefined)}$
$R = 100 \text{ ohms}$	$R = \text{Charging resistance (predefined)}$
$C = 300 \text{ µF}$	$C = \text{DC circuit capacity (5 x 15 µF x 4 inverters)}$
$T = R \times C \text{ (T = 0.03 s)}$	$T = \text{Time constant}$

$U_c = U_o \times \left(1 - e^{-\frac{t}{T}}\right)$	$U_c = 499.364 \text{ V}$	Capacitor voltage
--	---------------------------	-------------------

$U_r = U_o - U_c$	$U_r = 0.636 \text{ V}$	Voltage at charging resistor
-------------------	-------------------------	------------------------------

$U_r = U_o \times e^{-\frac{t}{T}}$	$U_r = 0.636 \text{ V}$	Voltage at charging resistor
-------------------------------------	-------------------------	------------------------------

$i = \left(\frac{U_o}{R}\right) \times e^{-\frac{t}{T}}$	$i = 6.363 \times 10^{-3} \text{ A}$	Effective charging current
--	--------------------------------------	----------------------------

$E_r = \int_0^t \left(\frac{U_o}{R}\right) \times e^{-\frac{t}{T}} \times U_o \times \left(e^{-\frac{t}{T}}\right) \times dt$	$E_r = 37.5 \text{ J}$	Charging energy
---	------------------------	-----------------

$E_c = \int_0^t \left(\frac{U_o}{R}\right) \times e^{-\frac{t}{T}} \times U_o \times \left(1 - e^{-\frac{t}{T}}\right) \times dt$	$E_c = 37.405 \text{ J}$	Charging energy
---	--------------------------	-----------------

$$P_r = \frac{E_r}{t}$$

$$P_r = 187.5 \text{ W}$$

Peak power

$$f = 0.1 \text{ Hz} ; T = 10 \text{ s}$$

$$P_{rm} = E_r \times f$$

$$P_{rm} = 3.75 \text{ W}$$

Average power

When $T = 5$ ($5 T = 5 \times 0.03 \text{ s} = 0.15 \text{ s}$), the capacitors are charged by 99.33% of U_o . Reserves of 0.05 s are available. The selected 100 ohm resistor must be designed for an average power of 3.75 watts and a peak power of 187.5 watts.

6.3.1.2 Calculation example – discharging circuit

Calculating an active discharge for the quad inverter by using of 3 watts of power resistors.

5 capacitors (each 15 μF) are connected in parallel for each inverter.

The discharge circuit should be activated with a normally open switch contact, if the HV circuit or the battery is disconnected.

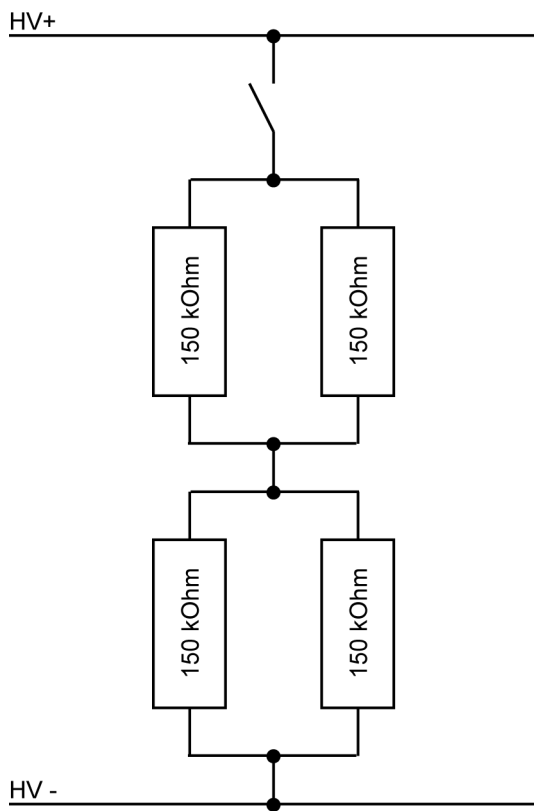

Calculation example:

$$U_o = 600 \text{ V}$$

$$R_1, R_2, R_3, R_4 = 150 \text{ kOhm}$$

$$C = 300 \mu\text{F}$$

U_o = HV battery voltage (DC circuit voltage)

R = Discharging resistance (predefined)

C = DC circuit capacity ($5 \times 15 \mu\text{F} \times 4$ inverters)

$$R_{ges} = \frac{R_1 \times R_2}{R_1 + R_2} + \frac{R_3 \times R_4}{R_3 + R_4}$$

$$R_{ges} = 1,5 \times 10^5 \Omega$$

Total resistance

$$I = \frac{U_o}{R_{ges}}$$

$$I = 4 \times 10^{-3} \text{ A}$$

Discharge current

$$P_v = \frac{U_o^2}{R_{ges}}$$

$$P_v = 2,4 \text{ W}$$

Maximum power loss all resistors

$$P_{v_R} = \frac{P_v}{4}$$

$$P_{v_R} = 0,6 \text{ W}$$

Maximum power loss each resistors

$$\tau = R_{ges} \times C$$

$$\tau = 45 \text{ s}$$

Time constant

Discharge time to prescribed residual voltage U_c

$$U_c = 50 \text{ V}$$

U_c = Residual voltage at capacitor

\ln = Logarithm naturalis

$$t = \tau \times \ln \left(\frac{U_o}{U_c} \right)$$

$$t = 111,821 \text{ s}$$

Discharge time in seconds until residual voltage U_c is reached

$$t_{Min} = \frac{t}{60 \text{ s}}$$

$$t_{Min} = 1,86 \text{ min}$$

Discharge time in minutes until residual voltage U_c is reached

Result:

With active discharge according to the calculation example a discharge time of 111.821 s (1.86 min) is needed, to be discharged to a residual voltage of 50 VDC.

Residual voltage to prescribed discharge time t

$$t = 300 \text{ s}$$

t = Discharge time

$$U_c = U_o \times e^{-\frac{t}{\tau}}$$

$$U_c = 1 \text{ V}$$

Result:

After 300 s discharge time, the residual voltage is 1 volt.

6.3.2 PE ground connection – overview

A highly conductive connection must be implemented in the vehicle to provide the ground connection. This is used as a 0 VDC ground for all signal and operating voltages. For vehicles without a metal frame, a ground strap made from a braiding of fine copper wires can be used.

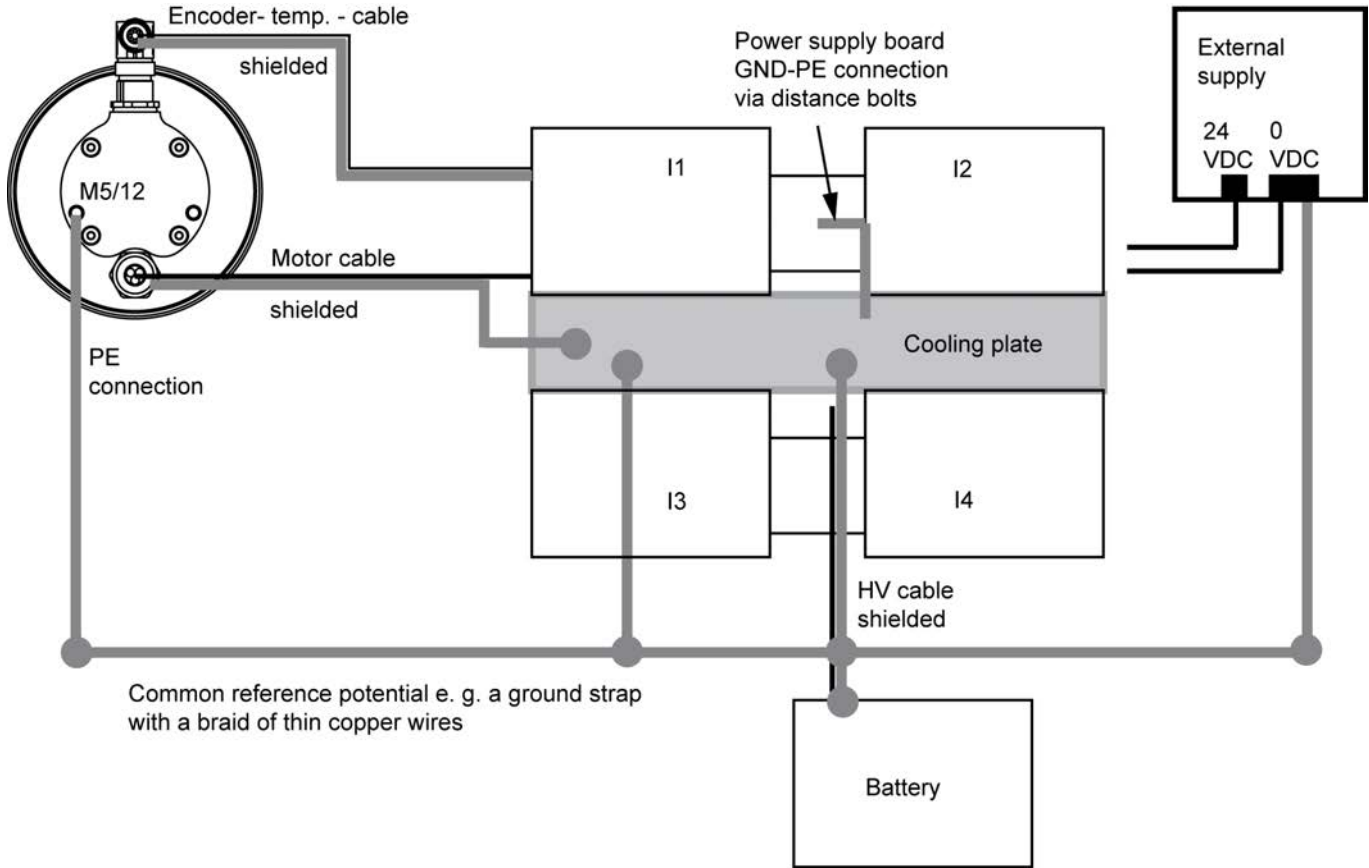

Motor cable

The motor cable must be a shielded cable with tinned copper braiding. The motor cable shield must be connected to the shield for the unconnected cable end of the motor across the surface. Use non-adhesive heat-shrink tubing for this. Press the two pieces of shielding firmly together.

At the inverter, the shield must be placed across the surface of the cold plate. Ensure good contact with the cold plate.



The motor cable shield can prevent interference to a large extent.
(Large diameter → skin effect)

HV cable

When greater than 1 m, the HV cable must have a copper shield.

The end of the shield must be connected to the designated casing ground on the cold plate and on the battery side.



The end of the shield must NOT be connected to the negative terminal (-) of the HV battery.

Encoder temp. cable

The encoder cable shield must be grounded on both sides.

Via the circular connector casing on the motor and via the metalized D-SUB casing on the inverter (connection X131).

Power supply board

The power supply board GND is connected to the cold plate via the standoffs.

Cold plate

The cold plate must be connected to the common vehicle ground.

External power supply

The 0 VDC connection must be connected to the common vehicle ground.

6.3.2.1 GND and PE connection – power supply and logic board

The cold plate is the PE ground for the inverters. The user is responsible for connecting the cold plate to the vehicle PE with a cable strand/ground strap (10 mm²). The user is responsible for producing the PE connection point on the cold plate. The user can choose where to place the connection point between the cooling channel. The cooling channel must not be damaged when pre-drilling the connection screw for the PE connection. See 'Liquid cooling – inverter' on page 24.

The 0 VDC connection for an external 24 VDC power supply must also be connected to the vehicle PE by the user.

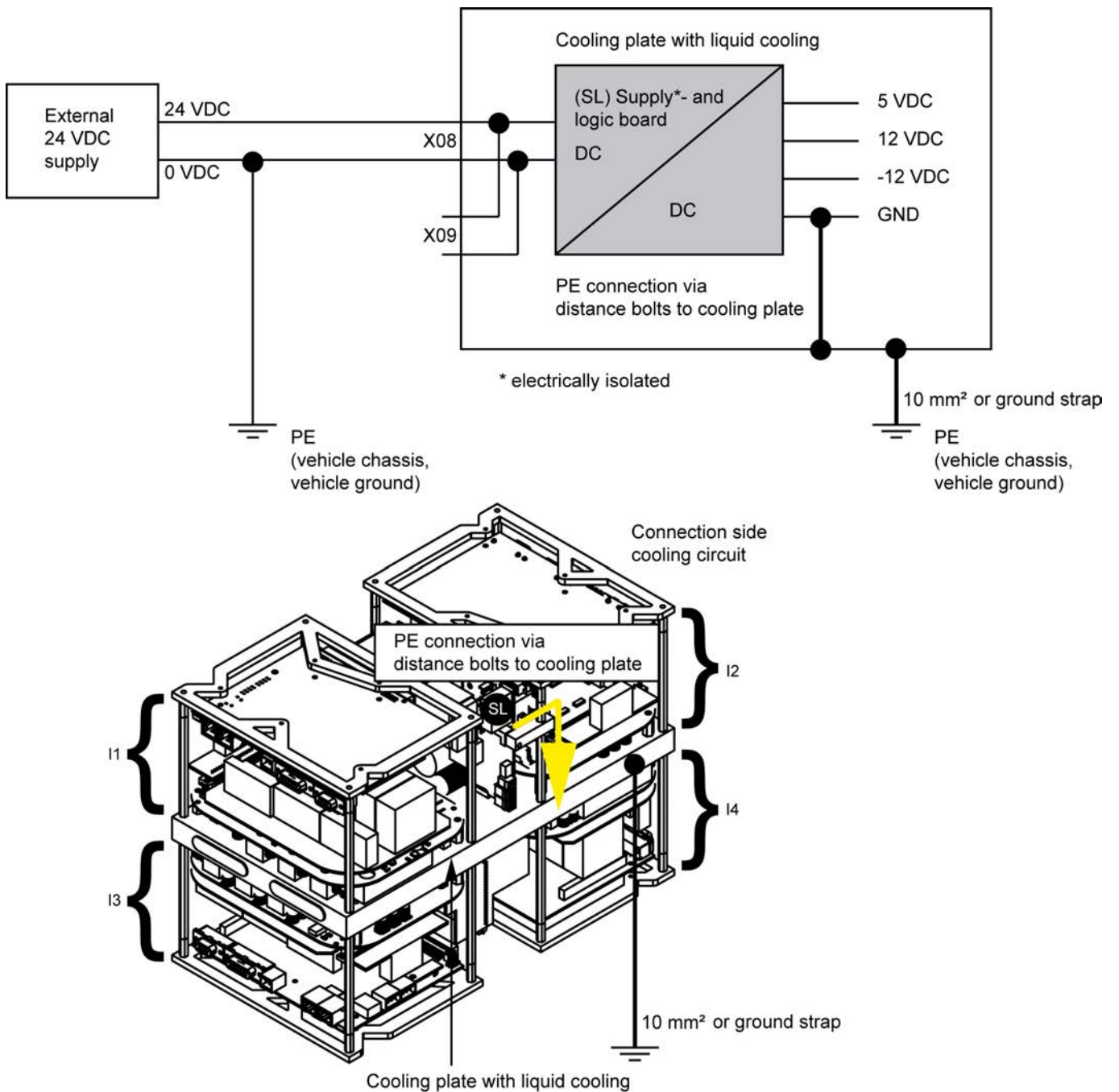

The PE connection is established in the same way for I1 + I2 and for I3 + I4 (on the rear of the device in the illustration).

6.4 Configuration

All AMK parameters are based on the SERCOS® standard and are described as identification (ID) numbers. They are described in the Parameter description KW-R06 / -R16 / -R07 / -R17 / -R27.

The inverter parameters are configured using the AMK AIPEX PRO startup software.



The FSE function is a special item of firmware in which some of the functionality and setting options for the parameters differ from the default parameter description and the selection options in AIPEX PRO.

Please refer to the following chapters for settings relevant to the FSE function.

6.4.1 Motor parameters



When the system is started up for the first time, the motor parameters are automatically transferred from the encoder database to the inverter.

The function is not performed if the motor parameters have already been entered manually. The AIPEX PRO's 'Initial program loading' function in direct mode allows the factory settings from AMK to be restored.

Prerequisite for the automatic transfer of the data from the encoder database:

- Encoder cable connected
- Motor parameters have not already been changed manually
- The data has been stored in the encoder at the factory

6.4.2 CAN bus communication parameters

The 'Communication parameters' group (instance 0) is used to enter the CAN bus specific values. They must be configured separately for each inverter.

ID34023 'BUS address participant'

Node number of the inverter in the CAN bus. Default value: 1

ID34024 'BUS transmit rate'

The same bus transmission rate must be set for all participants of a fieldbus system.

Default value: 0 (input in kbaud)

Input value: application-specific

ID34025 'BUS mode'

The 'BUS mode' defines the supported function specific to the field bus.

Default value: 0x2

Input value: 0x4 (meaning: customer-specific CAN)



The input ID34025 'BUS mode' must be entered with the AIPEX PRO direct mode.

Then execute the function in the AIPEX PRO menu 'Online' → 'Transfer parameters to project' → 'From current device'.

ID34028 'BUS output rate'

Default value: 0x0

Input value: 0x105 hex (meaning: 01 → Cyclic output, 05 → Output rate in ms)



ID34028 'BUS output rate' is a 'System internal parameter'.

The 'Parameter selection' button enables 'System internal parameters' to be displayed and enabled for editing.

Password: 500591

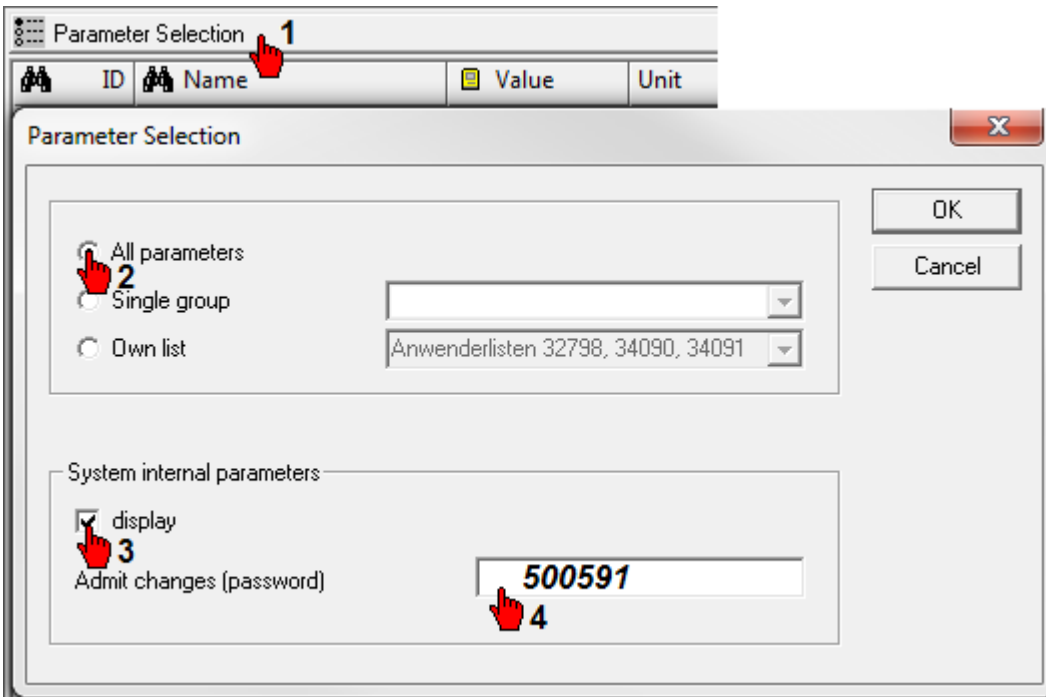

6.4.3 FSE parameters

ID32798 'User list 1'



ID32798 'User list 1' is used to configure the torque limitation when operating within limits. For description of function:

[See 'Torque limitation' on page 69.](#)

The user list must be configured on both a user-specific ¹⁾ and device-specific ²⁾ basis.

ID element	Dec value	Scaling	Meaning
32798 - 2	1 ²⁾	-	Operating mode (FSE = 1)
32798 - 3	720 ^{1,2)}	V	Maximum battery voltage (end-of-charge voltage) (user-specific value, max. 720 VDC)
32798 - 4	250 ^{1,2)}	V	Minimum battery voltage (deep discharge) (user-specific value, min. 250 VDC)  The value in ID32837 'DC bus voltage monitoring' must be adapted to ID32798 - 4 'Minimum battery voltage'.
32798 - 5	500 ²⁾	0.1 °C	Inverter temperature up to which full torque is available
32798 - 6	600 ²⁾	0.1 °C	Inverter temperature at which no torque is available
32798 - 7	670 ^{1,2)}	V	Start of reduction for end-of-charge voltage (user-specific value, at least 5% below the maximum battery voltage (ID32798 - 3)). If oscillation occurs, a value > 5% must be selected)
32798 - 8	1150 ²⁾	0.1 °C	Power supply temperature up to which full torque is available
32798 - 9	1250 ²⁾	0.1 °C	Power supply temperature at which no torque is available
32798 - 10	300 ^{1,2)}	V	Start of reduction for deep discharge protection (user-specific value, at least 20% higher than the minimum battery voltage (ID32798 - 4)).
32798 - 11	1250 ²⁾	0.1 °C	Motor temperature up to which full torque is available
32798 - 12	1400 ²⁾	0.1 °C	Motor temperature at which no torque is available

Configuring the user list

Convert the user list type from hexadecimal 'Hex' to decimal 'Dec' view.

Parameter Selection					
ID	Name	Value	Unit	Length	Type
32798	User list 1	1 RMB			Hex
32800	AMK main op. mode				Dec
32801	AMK second op. mode 1				Dec
32802	AMK second op. mode 2				Dec
32803	AMK second op. mode 3				Dec
32804	AMK second op. mode 4				Dec
32805	AMK second op. mode 5				Dec

<ul style="list-style-type: none"> ID standard type representation ID decimal representation ID hexadecimal representation ID binary representation ID IP representation Structured lists display 					
---	--	--	--	--	--

Enter the length of the list (maximum length of the list 245).

Parameter Selection					
ID	Name	Value	Unit	Length	Type
32798	User list 1	1		*2	Dec

Parameter Selection					
ID	Name	Value	Unit	Length	Type
32798	User list 1	245		*2	Dec

Click the 'Folder' icon to open the list.

You can then enter the predefined values in the list elements.

Parameter Selection					
ID	Name	Value	Unit	Length	Type
32798	User list 1	245		*2	Dec
32798-1	[maximum]	[254]			
32798-2		1			Dec
32798-3		800			Dec
32798-4		300			Dec
32798-5		500			Dec
32798-6		0			Dec

6.4.4 Default parameters

The 'Operating mode parameters' group is used to set the main operating mode.

ID32800 'AMK main operating mode'

Default value: 0x3C0043

Input value: 0x480003 (meaning: speed control with torque limitation as per ID82/83, setpoint source 0x48)

The 'System parameters' group is used to set the controller enable RF source hardware.

ID32796 'Source RF'

Default value: 0 dec

Input value: 5 dec (meaning: RF via fieldbus)



To activate motor control, you always require the RF hardware signal (X140 BE1) and the AMK_bEnable and AMK_bInverterOn CAN signals.

The 'System parameters' group is used to activate the FSE special function.

ID32901 'Global service bits'

Default value: 0x240

Input value: 0x10240 (meaning: FSE special function active)

The 'General parameters' group is used to activate I²t motor monitoring.

ID32773 'Service bits'

Default value: 0000 0000 0000 0000 0001 0000 0000 0101 (0x1005)

Input value: 0000 0000 0000 0000 0101 0000 0000 0101 (0x5005) (also set 'Motor monitoring active' for default bit 14 I²t)

The 'Motor parameters' group is used to enter the maximum speed.

ID113 'Maximum speed'

Default value: 6000

Input value: application-specific



If the actual speed value increases to the value in ID113 x 1.25, the output stage is blocked automatically and the motor runs down. The user must define the value for ID113 subject to the process without exceeding the maximum speed of the motor.

The 'Speed controller parameters' group is used to enter the speed limit.

ID38 'Positive velocity limit'

ID39 'Negative velocity limit'

Default value: +(-) 5000

Input value: application-specific (meaning: ID38/ID39 limits the speed setpoint)

The 'Inverter parameters' group is used to enter minimum allowed battery voltage.

ID32837 'DC bus voltage monitoring'

Default value: device specific

Input value: ID32798 - 4 'Minimum allowed battery voltage'

Exceeds the HV voltage the value in ID32798 - 4, the internal signal AMK 'QUE' will be set and the motor control can be activated.

6.4.5 Direction of rotation for motor shaft

If the setpoint is positive, the motor rotates in a clockwise direction (default setting) when looking at the motor shaft (A bearing side).

To reverse the direction of rotation without having to alter the coordinate view of setpoints and actual values, reverse the polarity of the setpoints and actual values by setting ID32773 'Service bits' bit 16 = 1.

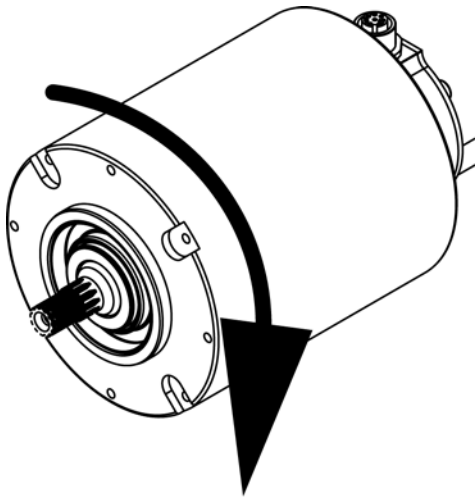

ID32773 Bit16 = 0

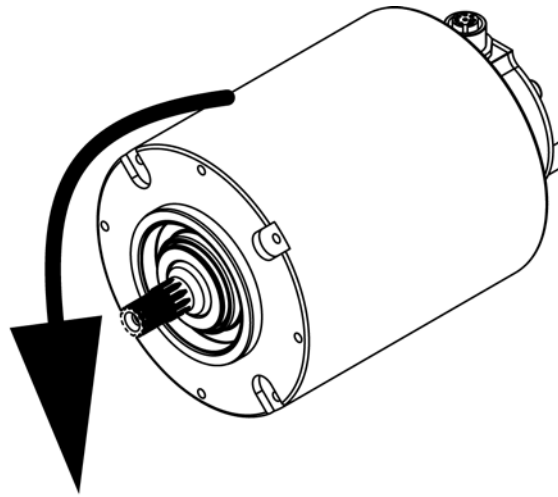

ID32773 Bit16 = 1

6.5 Synchronous servo motor with and without field weakening

6.5.1 Synchronous servo motor without field weakening

For a synchronous servo motor the maximum motor torque value is available up to the 'characteristic speed point'. After the 'characteristic speed point' the maximum motor torque decreases with increasing speed. When the motor reach the theoretical no-load-speed, the motor torque is 0 Nm.

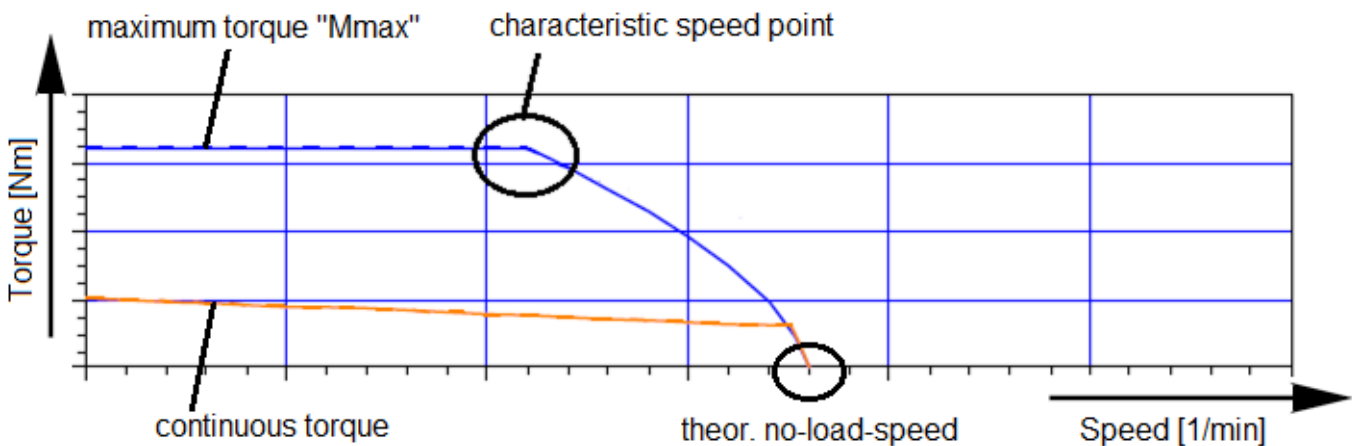

This is due to with the speed increasing induced voltage of the motor.

When approaching the induced voltage at the maximum output voltage of the inverter, the torque-generating current I_q reduced. Sequence, the motor torque decreases.

The maximum output voltage of the inverter is limited by the HV voltage.

When operating points on the 'characteristic speed point', the control reserve for the current controller is severely limited.

If you are using a battery, the HV voltage can vary by acceleration or recuperation. The HV voltage has a direct influence on the 'characteristic speed point'.

The induced voltage can be calculated using the following formula:

$$\text{Induced voltage} = \frac{\text{ID34234 'Voltage constant } K_e' \times \text{act. speed value} \times \sqrt{2}}{1000}$$

6.5.2 Synchronous servo motor with field weakening

A synchronous servo motor with field weakening can reach higher speeds with simultaneously, slowly reducing engine torque.

In addition, control reserves be achieved in the area of 'characteristic speed point'.

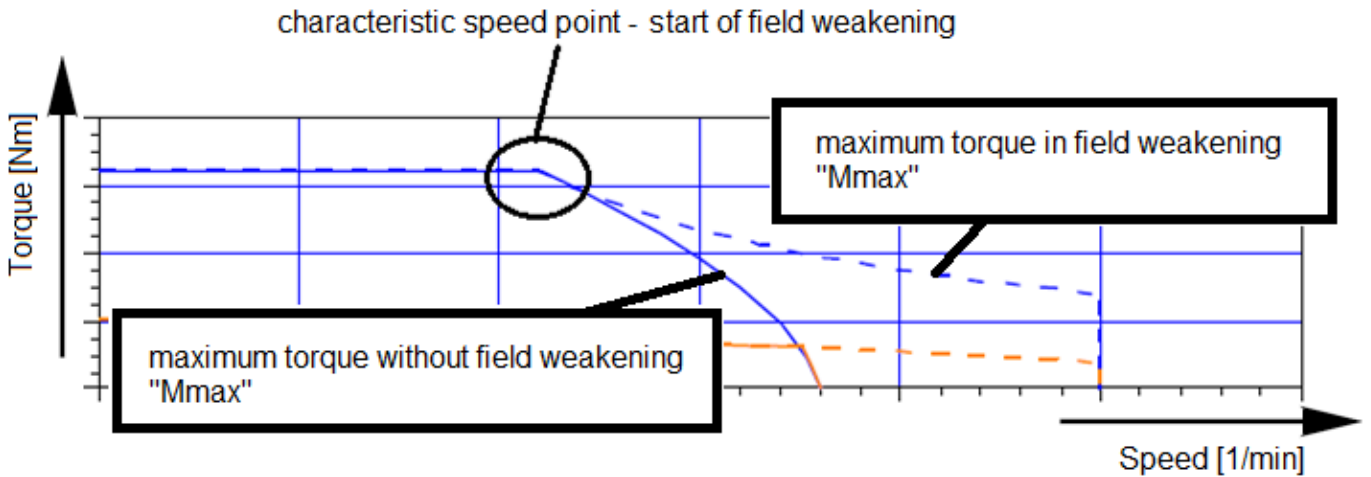

During the transition to the field weakening, the inverter injects in the winding a negative magnetization current I_d . Thereby, the field of the permanent magnet is weakened. The 'voltage constant K_e ' decreases, which reduces the induced voltage. A torque-generating current I_q can flow.



The magnetization current I_d caused losses. The maximum motor current " I_{max} " must not be exceeded.

$$I_{max} \geq \sqrt{I_q^2 + I_d^2}$$

6.5.3 Characteristics of motor power and motor torque



The following illustrations are exemplary characteristics.

The maximum motor power depends on the available HV voltage.
 Example: Motor power at 600 VDC and 500 VDC / - - - field weakening area

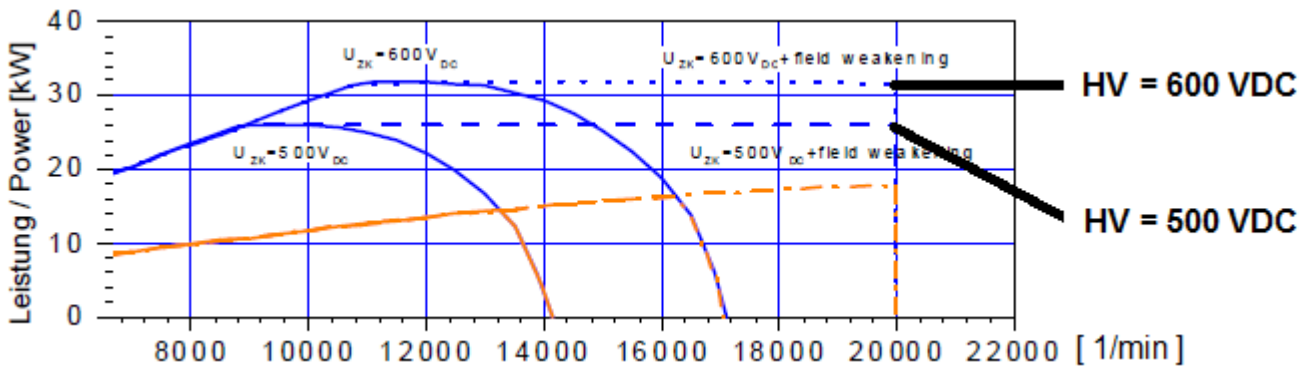

The transition into the field weakening (characteristic speed point) collaborates with reduced HV voltage earlier. The maximum motor torque falls generally in field weakening. In addition, the torque falls with reduced HV voltage. Example: Motor torque at 600 VDC and 500 VDC / - - - field weakening area

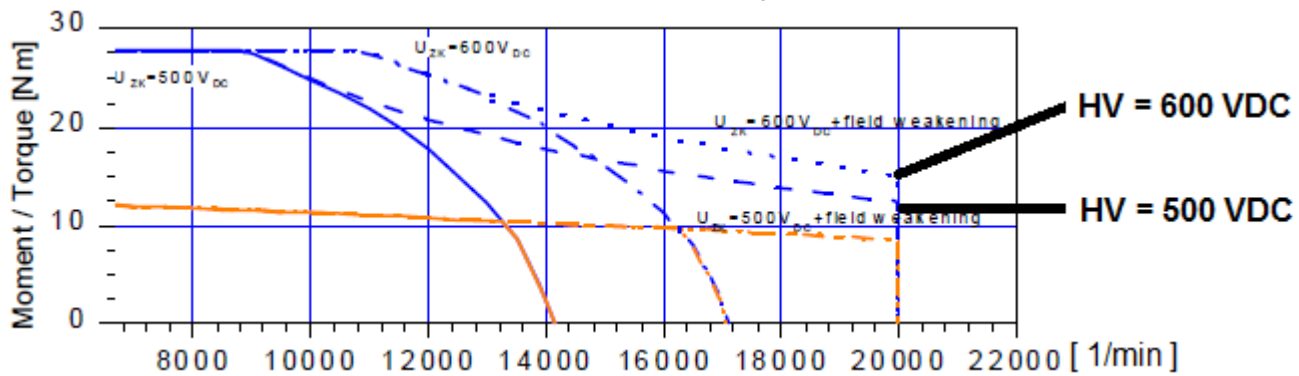

6.5.4 Torque setpoint in field weakening

⚠ WARNING	
	<p>Risk of unstable controller behavior</p> <p>The torque setpoint may not be higher than the maximum torque that can be made available from the motor at the current operating point.</p> <p>Possible consequences:</p> <ul style="list-style-type: none"> • Output terminal overcurrent (diagnoses-no. 2334), drive runs down • Drive runs down (induced voltage > HV voltage = DC braking) <p>Steps to prevent:</p> <ul style="list-style-type: none"> • Calculate maximum nominal torque specification and limit online



The maximum motor torque in the field weakening depends on the HV voltage. Change in the HV voltage, especially when accelerating must be taken into account by the user.

Below is an example, how to calculate the maximum allowed torque setpoint.

The maximum allowed torque setpoint $[M_{sollmax}]$ in dependence on the actual speed and the available motor power. The motor power is dependent on the HV voltage.

$$M_{soll\ max} = \frac{P [W]}{2 \times \pi \times \frac{N_{ist} [1/min]}{60}}$$



Locate on a test bench, the maximum motor power. Start the measurement series with a reduced motor power.

Determining field-weakening

The motor is in field weakening, if

$$M_{soll\ max} < M_{max}$$



The desired torque setpoint (in field weakening) by the CAN variables 'AMK_TorqueLimitPositiv' or 'AMK_TorqueLimitNegativ'

must be : $M_{setpoint} < M_{sollmax} < M_{max}$.

7 Electrical connections

7.1 Interface overview and connections – inverter

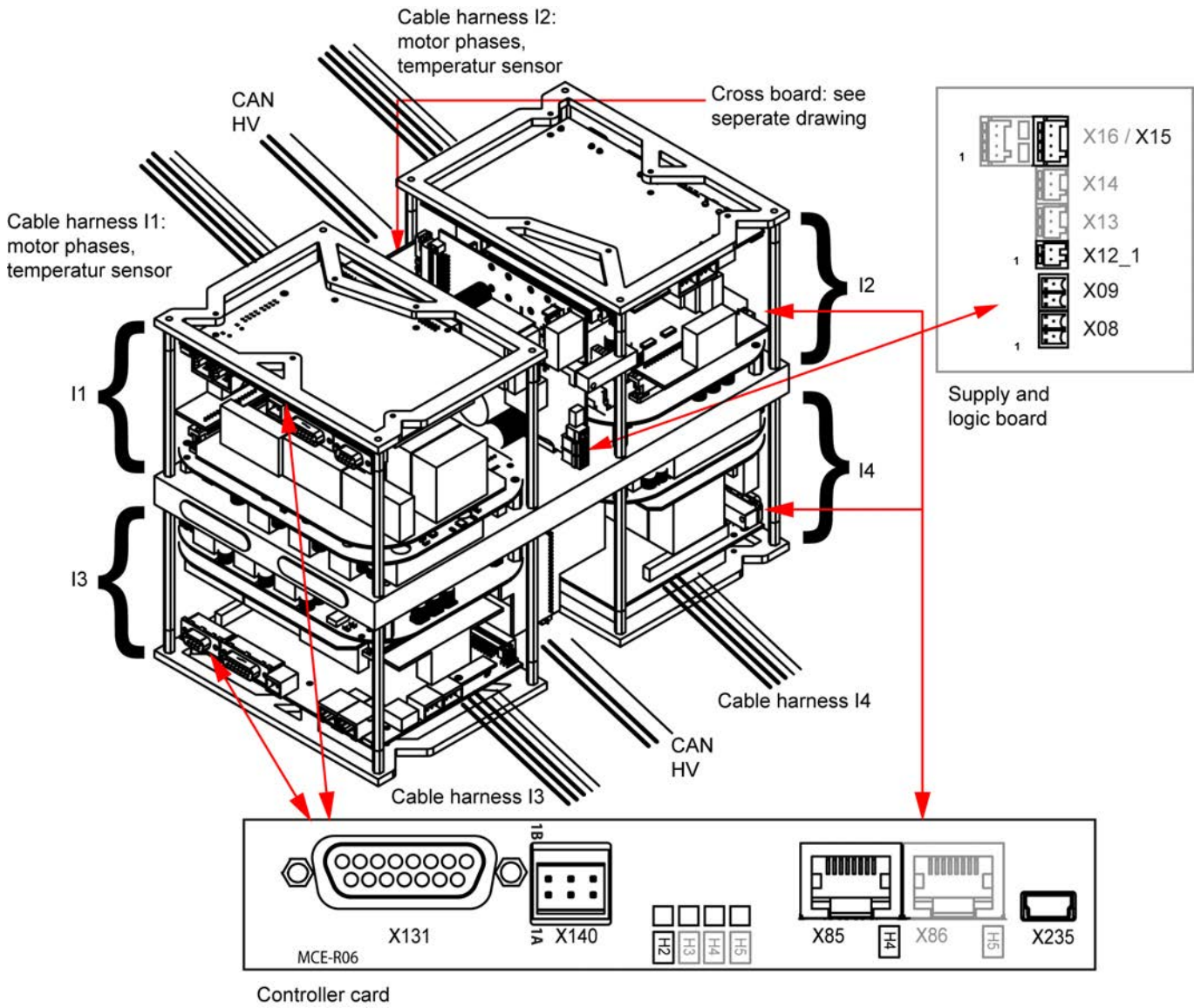

Transverse board terminal X12_2

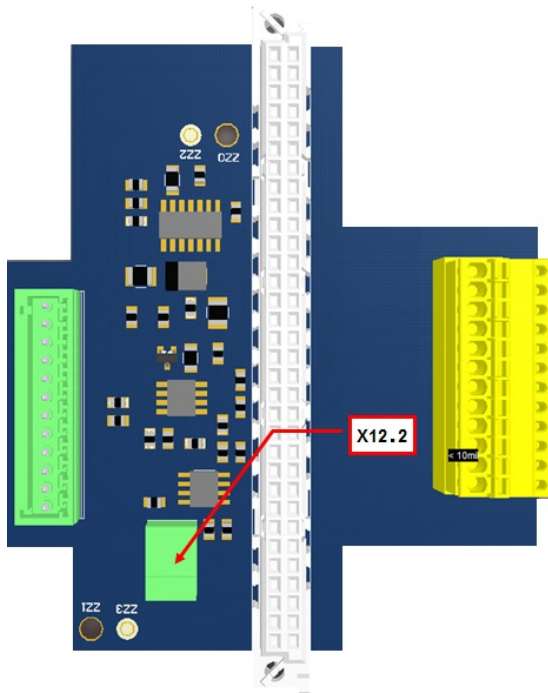

Overview of terminals

Interfaces	Number	Function
X08 / X09	2	Input for 24 VDC external supply (on-board supply) / 24 VDC routing ¹⁾
X12	4	Motor temperature monitoring
X13	2	Reserved
X14	2	Reserved
X15	2	Output stage enable ¹⁾
X16	2	Reserved
X85	4	Ethernet IN (EtherCAT) real time (connection to PC for AMK AIPEX PRO software (startup, diagnosis, and configuration) and ATF (firmware update))
X86	4	Reserved
X131	4	Motor encoder P encoder input, EnDat 2.1 (digital)
X140	4	Binary inputs
X235	4	USB (connection to PC for AMK AIPEX PRO software (startup, diagnosis, and configuration) and ATF (firmware update))

1) Common connection for I1 + I2 and I3 + I4

Overview of cable harness / open wire ends

Interfaces	Number	Function
HV+	2	Battery connection + ¹⁾
HV-	2	Battery connection - ¹⁾
U	4	Motor phase U
V	4	Motor phase V
W	4	Motor phase W
T-mot	4	Motor temperature monitoring
CAN bus	2	CAN specification 2.0 B as per ISO 11898 ¹⁾

1) Common connection for I1 + I2 and I3 + I4

Status LED H2

Class	Status	Note
Drive status	Green	System Ready (SBM)
	Green flashing	Drive under control (SBM and QRF)
	Orange flashing	Warning occurs during active controller enable
	Orange	Warning occurs during inactive controller enable / flash mode
	Red	Error with reaction depending on the error number

7.1.1 Stranded wires – CAN

Description:

Communication between the inverters and the higher-level controller takes place via a CAN bus. Clearly defined CAN messages are implemented for exchanging information.

See 'Data telegrams' on page 60.

Technical data:

- CAN specification 2.0 B as per ISO 11898

Design:

Design	Pins	Length	Type	Manufacturer	Description
14 mm ² single conductors, screw-type	3 x 1	Approx. 30 cm	Shielded cable	Unitron	LiYCY (shielded)

Assignment:

Signal	Color mark	Description
CAN High	White	CAN data cable +
CAN Low	Brown	CAN data cable -
CAN GND	Green	GND
-	Black	Cable shielding

7.1.2 Stranded wires – HV+ and HV-

 **DANGER**

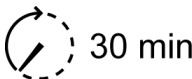
  30 min	<p>Danger to life from electric shock!</p> <p>After switching off the HV circuit, the buffer capacitors for the DC bus can still have a charge and lead to a life-threatening DC voltage if they are not discharged via an external circuit.</p> <p>Steps to prevent:</p> <ul style="list-style-type: none"> • Prior to all work on the device, the HV power supply is to be separated from the main switch and secured against restarting. • After switching off, expect a discharge time of at least 30 minutes. • Measure the terminal voltage, e.g. in the HV DC bus between the HV+ and HV- terminals to ensure that the terminal is voltage-free. • Caution: A voltage-free state is not signalled! • Use external discharge circuit. See 'Calculation example – discharging circuit' on page 30.
---	--

Description:

Supply voltage from the high-voltage battery for the DC link

HV +: connection to HV voltage +

HV -: connection to HV voltage -

Technical data:

- See 'Technical data – inverter' on page 15., HV voltage, DC link

Design:

Design	Pins	Length	Type	Manufacturer
10 mm ² single conductors, screw-type	2 x 1	Approx. 30 cm	Silicone wire	Multi Contact

Assignment:

Signal	Color mark	Description
HV +	Red	HV voltage +
HV -	Blue	HV voltage -

Connection:

Cable	2 single conductors, apply copper shield
Shield connection	Apply shield on both sides: <ul style="list-style-type: none"> • Cold plate • Connect the end of the shield on the battery side to the designated casing ground.

7.1.3 Stranded wires – motor temperature sensor

The stranded wires are connected to terminal X12.

See '[X12] motor thermistor for temperature monitoring' on page 47.

Design:

Design	Pins	Length	Type	Manufacturer	Description
0.34 mm ² single conductors, screw-type	2 x 1	Approx. 30 cm	Shielded cable	Unitron	LiYCY (shielded)

Assignment:

Signal	Color mark	Description
RT1 (+)	Brown	KTY + connection
RT2 (-)	White	KTY - connection
	Black	Cable shielding

7.1.4 Stranded wires – motor phases U, V, W

⚠ DANGER



Danger to life from touching electrical connections!

The permanent magnets of the rotor induce dangerous voltage at the motor connections when the axis rotates, even when the motor is not electrically connected. If the motor is connected to an inverter, the induced DC voltage is linked to the terminals HV.

Steps to prevent:

- Make sure that the motor shaft does not rotate.
- Make sure that shock-hazard protection is installed at the motor connections.
- Make sure that the terminals HV are free of voltage.

⚠ WARNING	
	<p>Danger from uncontrolled movements of the motor shaft!</p> <p>An incorrect phase sequence with the motor connection can lead to uncontrolled movements of the motor shaft after being powered on.</p> <p>Steps to prevent:</p> <ul style="list-style-type: none"> • Ensure that the motor phases are correctly connected.

Description:

Connection of the U, V, W phases of the motor

Technical data:

- See 'Technical data – inverter' on page 15.

Design:

Design	Pins	Length	Type	Manufacturer	Description
6 mm ² single conductors, soldered	3 x 1	Approx. 30 cm	Stranded wire	RADOX®	155 stranded wire

Assignment:

Signal	Color mark	Description
U	Brown	Phase U motor voltage
V	Blue	Phase V motor voltage
W	Black	Phase W motor voltage

Connection:

Cable	3 single conductors, shielded
Shield connection	Apply shield on both sides: <ul style="list-style-type: none"> • Cold plate • Shield end applied on the motor side by AMK

7.1.5 [X08] / [X09] 24 VDC supply voltage (on-board supply) and looping

NOTICE	
Material Damage!	<p>Overload of the terminal and the internal circuit board!</p> <p>The connected rating of the terminals X08, X09 is restricted. The terminals X08 or X09 are designed for a current of at most 8 A.</p> <p>Steps to prevent:</p> <ul style="list-style-type: none"> • A looping of the 24 VDC supply voltage is permitted for a total of 5 modules at the most. • If more than 5 devices are installed, each group of five needs to be supplied separately with 24 VDC.

NOTICE	
Material Damage!	<p>Material damage caused by incorrect handling!</p> <p>Mechanical damage to terminals! Disconnected signal lines.</p> <p>Steps to prevent:</p> <ul style="list-style-type: none"> • The plug connectors are partially encoded. Do not push in with force. • Never pull on the cable, but rather on the connector casing. • For service purposes, use the control tap.

Description:

For supplying the internal switched-mode power supply

X08: connection to 24 VDC supply voltage

X09: voltage looping





Technical data:

- 24 VDC ±15%
- Ripple max. 5% with integrated inrush current limitation
- The 0 V potential of the power supply is to be grounded at the central PE

Design:

Design	Pins	Type
Connector with tension spring connection	2	Single-row pin strip

Assignment:

[X08] / [X09]	Connection	Signal	Description
front view, device side X09 PIN 2  X09 PIN 1  X08 PIN 2  X08 PIN 1 	1	0 VDC	Connection 0 VDC logic supply
	2	24 VDC	Connection 24 VDC logic supply

Connection:

Recommended cable type	2-wire, unshielded
Cable assembly	Flexible cable or ferrule without plastic sleeve
Min. / max. cross section	0.25 mm ² / 1.5 mm ² AWG 24 / AWG 16
Recommended cable cross section	0.75 mm ² AWG 18
Cable stripping length	9 mm
Terminal	FK-MCP 1.5/2-ST-3.80
Note	A failure of the 24 VDC supply that lasts > 10 ms will result in a fault

7.1.6 [X12] motor thermistor for temperature monitoring

NOTICE	
Material Damage!	<p>Material damage resulting from Overheating!</p> <p>AMK servo motors are provided with sensors for temperature monitoring. Motors without or with bypassed PTC thermistor can overheat and be destroyed.</p> <p>Steps to prevent:</p> <ul style="list-style-type: none"> • Connect the PTC thermistor of the servo motor for temperature monitoring • Activate the I²t monitoring of the servo motor in ID32773 'Service bits' Bit 14.
NOTICE	
Material Damage!	<p>Material damage caused by incorrect handling!</p> <p>Mechanical damage to terminals! Disconnected signal lines.</p> <p>Steps to prevent:</p> <ul style="list-style-type: none"> • The plug connectors are partially encoded. Do not push in with force. • Never pull on the cable, but rather on the connector casing. • For service purposes, use the control tap.

Description:

Connection for monitoring the temperature of a servo motor (can be configured via ID34166 'Temperature sensor motor'). The X12 terminal is prewired with two strands. See 'Stranded wires – motor temperature sensor' on page 44.

Assignment:

Inverter W2 and inverter W4: connection X12_1

Inverter W1 and inverter W3: connection X12_2



Technical data:

- Temperature sensor (KTY)

Design:

Design	Pins
Connector with tension spring connection	2

Assignment:

[X12]	Connection	Signal	Description
front view, device side	1	RT1 (+)	Connection temperature sensor, take care of the polarity at KTY!
PIN 2  PIN 1 	2	RT2 (-)	Connection temperature sensor, take care of the polarity at KTY!

Connection:

Recommended cable type	2-wire, shielded
Cable assembly	Flexible cable or ferrule without plastic sleeve
Shield connection	Apply on one side on module casing

Min. / max. cross section	0.25 mm ² / 0.5 mm ² AWG 24 / AWG 20
Recommended cable cross section	0.5 mm ² AWG 20
Cable stripping length	8 mm
Terminal	FK-MC 0.5/2-ST-2.5

7.1.7 [X15] output stage enable (2-channel)

NOTICE

Material Damage!	Material damage caused by incorrect handling! Mechanical damage to terminals! Disconnected signal lines.
	Steps to prevent: <ul style="list-style-type: none"> • The plug connectors are partially encoded. Do not push in with force. • Never pull on the cable, but rather on the connector casing. • For service purposes, use the control tap.

Description:

During normal operation, the inputs 'EF' and 'EF2' must be set simultaneously. This enables the power output stage.

An interruption to 'EF' and 'EF2' leads to the clock pulses for the power output stage being immediately and reliably blocked. If the controller enable (RF) is set, an error message is generated and the power output stage is blocked. See 'Drive behavior in the event of an error' on page 66.

Technical data:

- Electrically isolated via optocoupler
- Rated input voltage: +24 VDC ext.
- Pin 3 coding

Design:

Design	Pins
Connector with tension spring connection	4

Assignment:

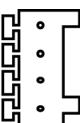
[X15]	Connection	Signal	Description
front view, device side PIN 4 PIN 3 PIN 2 PIN 1 	1	EF2	Power output stage enable EF2
	2,4	EF	Power output stage enable EF
	3	WEF	Reference potential 0 V ext. for the input current to EF / EF2

Connection:

Recommended cable type	4-wire, unshielded
Cable assembly	Flexible cable or ferrule without plastic sleeve
Recommended cable cross section	0.5 mm ² AWG 20
Cable stripping length	8 mm
Terminal	FK-MC 0.5/4-ST-2.5

7.1.8 [X85] real-time Ethernet (EtherCAT)

Description:

The interface is designed as a real-time Ethernet interface and supports the EtherCAT SoE protocol (servo drive profile over EtherCAT (SoE) according to IEC 61800-7-300).

The EtherCAT interface enables the controller card to be connected to a PC and the installed AMK AIPEX PRO software for the purposes of startup and diagnosis.

X85: PC connection

X86: reserved

Technical data:

- 100BASE-T 100 Mbit/s Ethernet standard
- Data frame and assignment of the RJ45 socket according to IEEE 802.3
- Maximum length 50 m (industrial environment)

Design:

Design	Pins	Type
RJ45	8	Socket

Assignment:

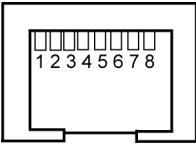
[X85] / [X86]	Pin	Signal	Description
front view, device side 	1	Tx+	Transmit data +
	2	Tx-	Transmit data -
	3	Rx+	Receive data +
	4	-	Reserved
	5	-	Reserved
	6	Rx-	Receive data -
	7	-	Reserved
	8	-	Reserved

Connection:

Cable type	CAT5e patch cable, shielded
Min. / max. cross section	0.32 mm ² / AWG 22
Shield connection	On both sides
Cable assembly	RJ45 plug
Note	-

7.1.9 [X131] motor encoder

NOTICE

Material Damage!	<p>Electronic components could be destroyed through static discharge!</p> <p>Therefore touching of the electrical connections (e. g. signal and power supply cable) must be avoided. Otherwise you can be damaged the components when touching by static discharge.</p> <p>Steps to prevent:</p> <ul style="list-style-type: none"> • Avoid touching electrical connections and contacts. • During handling the electronic component discharge yourself by touching PE. • Pay attention to the ESD-notes (electrostatic discharge).
-------------------------	--

Description

AMK type P motor encoders are installed in the RACING KIT. For further information: [See 'Motor encoders' on page 70.](#)

Technical data

- Input signals as per RS485 specification
- Encoder cable lengths:

Encoder description	ECI 1118
AMK encoder description	P
Max. encoder cable length [m]	100



The specified cable lengths are valid in conjunction with the specified voltage ranges and the cable cross sections recommended by AMK.

Design

Design	Pins	Type
D-SUB	15	Socket

Assignment

[X131]	Connection	P-encoder
front view, device side 	1	-
	2	-
	3	-
	4	-
	5	-
	6	-
	7	5 VDC ¹⁾
	8	GND
	9	-EN_DAT
	10	+EN_DAT
	11	-EN_CLK
	12	+EN_CLK
	13	5 VDC ¹⁾
	14	GND
	15	-

1) 5 VDC ±5 % max. 350 mA

Connection

	P
Cable	4 x 2 x 0.25 mm ² twisted pair, + 4 x 0.5 mm ² shielded
Shield connection	Apply on both sides
Cable assembly	D-SUB 15-pin plug, with metalized casing
Note	The cable shield is grounded on the motor side by means of the fitting in the plug casing.



Recommended cable type:

M12 plug, 8-pin, tightening torque 0.4 Nm
 Minimum cross section 0.25 mm², shielded

The connection cable with angled plug and data cables is available for order from:
 Phoenix Contact, description: SAC-8P-M12MR/5,0-PUR SH
 (not part of the AMK RACING KIT)

Controller input circuit

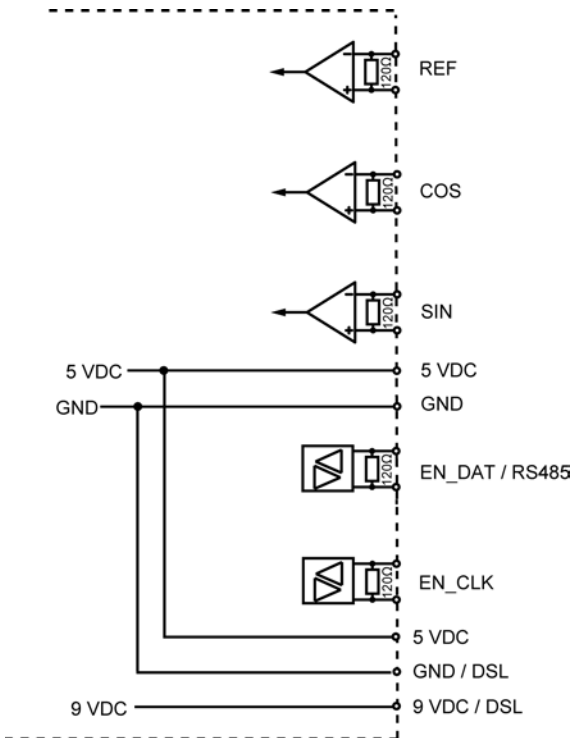

Encoder signal evaluation

In ID32953 'Encoder type' is defined how to evaluate the incoming encoder signals.

7.1.10 [X140] binary inputs and outputs

NOTICE	
Material Damage!	<p>Electronic components could be destroyed through static discharge!</p> <p>Therefore touching of the electrical connections (e. g. signal and power supply cable) must be avoided. Otherwise you can be damaged the components when touching by static discharge.</p> <p>Steps to prevent:</p> <ul style="list-style-type: none"> • Avoid touching electrical connections and contacts. • During handling the electronic component discharge yourself by touching PE. • Pay attention to the ESD-notes (electrostatic discharge).

Description

At terminal X140, the controller card has 2 binary inputs and 1 binary output. The FSE firmware uses the 2 binary inputs.

Technical data

- Norm IEC 61131-2 type 3 binary inputs:
 Rated input voltage 0-30 VDC, maximal input current at 30 VDC = 15 mA
 Level 0-5 VDC: low, 11-30 VDC: high
 Electrically delay of $T_{on} = 3-8 \mu s$, $T_{off} = 48-57 \mu s$
- Norm IEC 61131-2 binary outputs:
 Rated output voltage 24 VDC, rated output current maximal 0.5 A, short-circuit safe, electrically isolated, electrically delay of $T_{on} 8-20 \mu s$, $T_{off} = 50-55 \mu s$ at 200 mA load

Design

Design	Pins	Type
Connector with tension spring connection	6	2-row pin strip

Assignment:

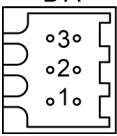
[X140]	Connection	Signal	Description
front view, device side B A 	1A	BA3	Binary output 3, 24 VDC, 2.5 A ¹⁾ , potential separated, permanently short-circuit safe .
	1B	BGND	Reference potential 0 V for supply of the binary inputs and outputs
	2A	BGND	Reference potential 0 V for supply of the binary inputs and outputs
	2B	BE2	Binary input 2, 24 VDC $\pm 15 \%$, max. 10 mA, potential separated, e.g. probe input, cam
	3A	BVCC	Supply of the binary outputs 24 VDC $\pm 15 \%$
	3B	BE1	Binary input 1, 24 VDC $\pm 15 \%$, max. 10 mA, potential separated, e.g. RF

FSE function – binary input BE1

Activating the controller enable also requires the hardware input BE1 to be set in addition to the CAN signals ('AMK_bInverterOn' and 'AMK_bEnable'). BE1 is similar to the terminal designation X15 (ignition key) in the automotive sector.

BE1 = 1 : controller enable RF possible

BE1 = 0 : controller enable RF blocked

FSE function – binary input BE2

Activating the predefined torque limits requires the BE2 hardware input to be set.

BE2 = 1 : torque limits active

BE2 = 0 : torque limits deactivated, motor without torque

Connection

Cable	6 x 0.8 mm ² (max.) / AWG 18, shielded
Shield connection	Apply on one side on module casing
Cable assembly	Weidmüller socket connector, 6-pin AMK part no. 202700

Circuit

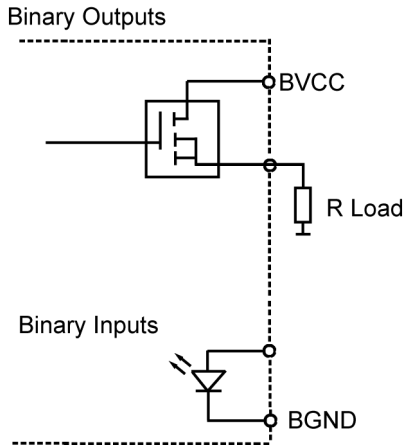

7.1.11 [X235] USB

Description:

The inverters have a mini USB interface, which can be used to connect them to a PC and the AIPEX PRO software for the purposes of startup and diagnosis.

Technical data:

USB V1.1 slave

Design:

Design	Pins	Type
USB V1.1 type A as per mini USB type B	5	Port

Assignment:

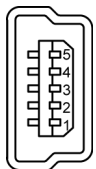
[X235]	Connection	Signal	Description
Front view, device side 	1	5 VDC input	External 5 VDC supply from USB master, power consumption max. 50 mA
	2	D-	Data -
	3	D+	Data +
	4	5 VDC	Reserved for AMK
	5	GND	Ground

Connection:

Cable type	Data+ and data- twisted pair, shielded
Min. / max. cross section	0.08 mm ² / AWG 28
Shield connection	Apply on both sides
Cable assembly	Assembled cables
Note	Max. length of 3 m permitted for USB cables. Larger cable lengths are possible with an active USB repeater.

7.2 Interface overview and connections – motor

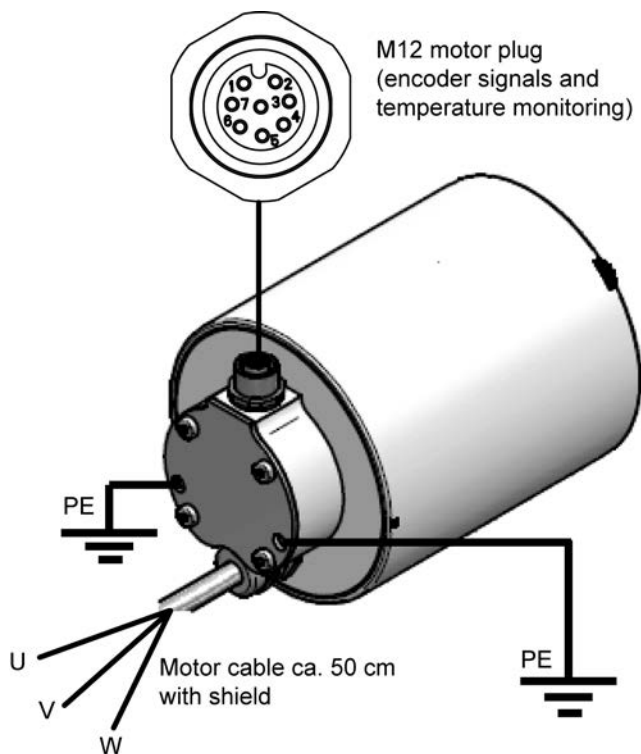

Coding motor phases

DD5

- U - Black
- V - Blue
- W - Brown

DT5 up to 2016 from 2017

- | | | |
|---|---------|---|
| U | - Brown | 1 |
| V | - Blue | 2 |
| W | - Black | 3 |

7.2.1 M12 motor connector (encoder signals and temperature monitoring)

NOTICE

Material Damage!

Electronic components could be destroyed through static discharge!

Therefore touching of the electrical connections (e. g. signal and power supply cable) must be avoided. Otherwise you can be damaged the components when touching by static discharge.

Steps to prevent:

- Avoid touching electrical connections and contacts.
- During handling the electronic component discharge yourself by touching PE.
- Pay attention to the ESD-notes (electrostatic discharge).

Description

Connection socket for encoder signals and temperature monitoring

Technical data

AMK type P motor encoder, EnDat 2.2 light (digital) ¹⁾

KTY temperature sensor

- 1) EnDat 2.2 light means, that the encoder supports EnDat 2.2, which is used only with the commands of EnDat 2.1 from the AMK controller.

Design

Design	Pins	Type
M12 socket	8	-

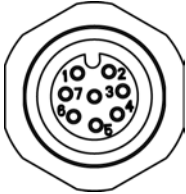
	Connection	Signal	Terminal on inverter	Name of connection on inverter	Description
	1	KTY-	X12 (unconnected cable end present)	RT2 (-)	Temperature sensor connection, observe polarity for KTY!
	2	KTY+		RT1 (+)	Temperature sensor connection, observe polarity for KTY!
	3	Data+	X131	+EN_DAT	Digital data signal
	4	Data-		-EN_DAT	Digital data signal (inverted)
	5	GND		GND	Ground
	6	Clock-		-EN_CLK	Clock signal
	7	Clock+		+EN_CLK	Clock signal inverted
	8	Up		5 VDC ±5% Max. 350 mA	Voltage supply

Connection



Recommended cable type:

M12 plug, 8-pin, tightening torque 0.4 Nm
Minimum cross section 0.25 mm², shielded

The connection cable with angled plug and data cables is available for order from: Phoenix Contact, description: SAC-8P-M12MR/5,0-PUR SH (not part of the AMK RACING KIT)



Connect shield across the surface and apply to connector X131.

7.2.2 Motor cable

⚠ DANGER	
	<p>Danger to life from touching electrical connections!</p> <p>The permanent magnets of the rotor induce dangerous voltage at the motor connections when the axis rotates, even when the motor is not electrically connected. If the motor is connected to an inverter, the induced DC voltage is linked to the terminals HV.</p> <p>Steps to prevent:</p> <ul style="list-style-type: none"> • Make sure that the motor shaft does not rotate. • Make sure that shock-hazard protection is installed at the motor connections. • Make sure that the terminals HV are free of voltage.

Description:

Connection of the U, V, W phases of the motor

Technical data:

- See 'Technical data – inverter' on page 15.

Design:

Design	Pins	Length	Type
4 mm ² single conductor, shielded	3 x 1	Approx. 50 cm	Stranded wires, shielded

Assignment motor type DD5:

Signal	Color mark	Description
U	Black	Phase U motor voltage
V	Blue	Phase V motor voltage
W	Brown	Phase W motor voltage

Assignment motor type DT5 (from 2017):

Signal	Coding	Description
U	1	Phase U motor voltage
V	2	Phase V motor voltage
W	3	Phase W motor voltage

Assignment motor type DT5 (up to 2016):

Signal	Color mark	Description
U	Brown	Phase U motor voltage
V	Blue	Phase V motor voltage
W	Black	Phase W motor voltage

Connection:

Cable	3-wire, minimum cross section 4 mm ² , shielded
Shield connection	Apply shield on both sides: <ul style="list-style-type: none"> • Cold plate • Connect the end of the shield on the motor side to the designated casing ground.



The cable shield must be continuous between the motor and inverter and applied on both sides. Unshielded cables can be shielded with a shielding braid. Allow transitions to overlap to a large extent.

7.2.3 PE connection

⚠ DANGER



Danger to life from electric shock!

In the event of an interruption to the PE connection, hazardous voltages may be present on the casing.

Preventive measures:

- The PE connection must be designed with a cable cross section of at least 10 mm².
- The PE connection is screwed into the motor casing with a ring cable lug and an M5 screw.

Connection:

Recommended cable type	1-wire at least 10 mm ² or ground strap
Cable assembly	Ring cable lug
Connection	M5 x 12

8 Functionality

8.1 CAN bus

8.1.1 Wiring for two CAN BUS lines

It is intended that one inverter pair (I1 + I2, or I3 + I4) will be operated at one common CAN.

A fieldbus cable approx. 30 cm in length is soldered in each inverter pair (I1 + I2, or I3 + I4). A 120 ohm bus terminator is integrated in the I2 and I4 inverters.

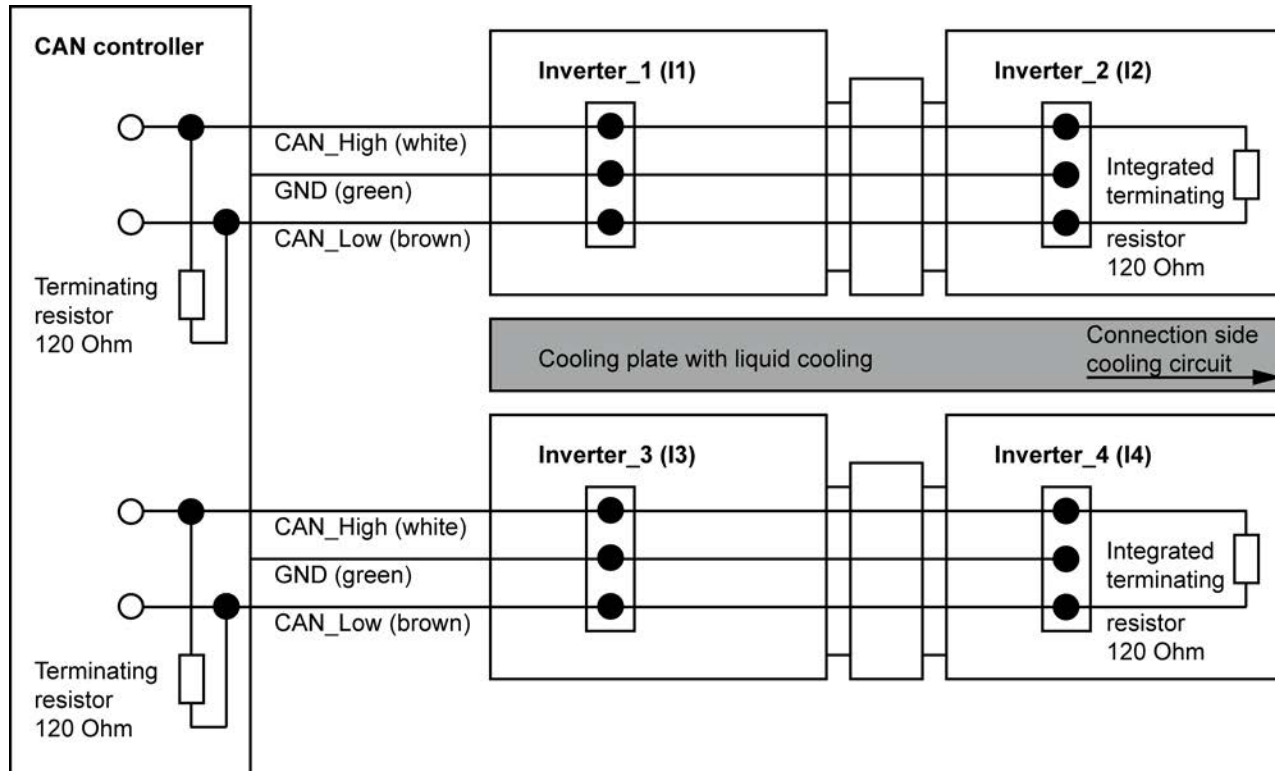

8.1.2 Wiring for one CAN BUS line



AMK recommends using 2 CAN bus lines.

See 'Wiring for two CAN BUS lines' on page 58.

The company AMK Arnold Müller GmbH & Co. KG is not liable for any damage arising from the transformation to one CAN line.

When remodeling to one CAN line the termination resistors (R314 and R316) must be unsoldered (in the example I2) Then connect the CAN interface X137 (I2) with the CAN interface of the following inverter (I3).

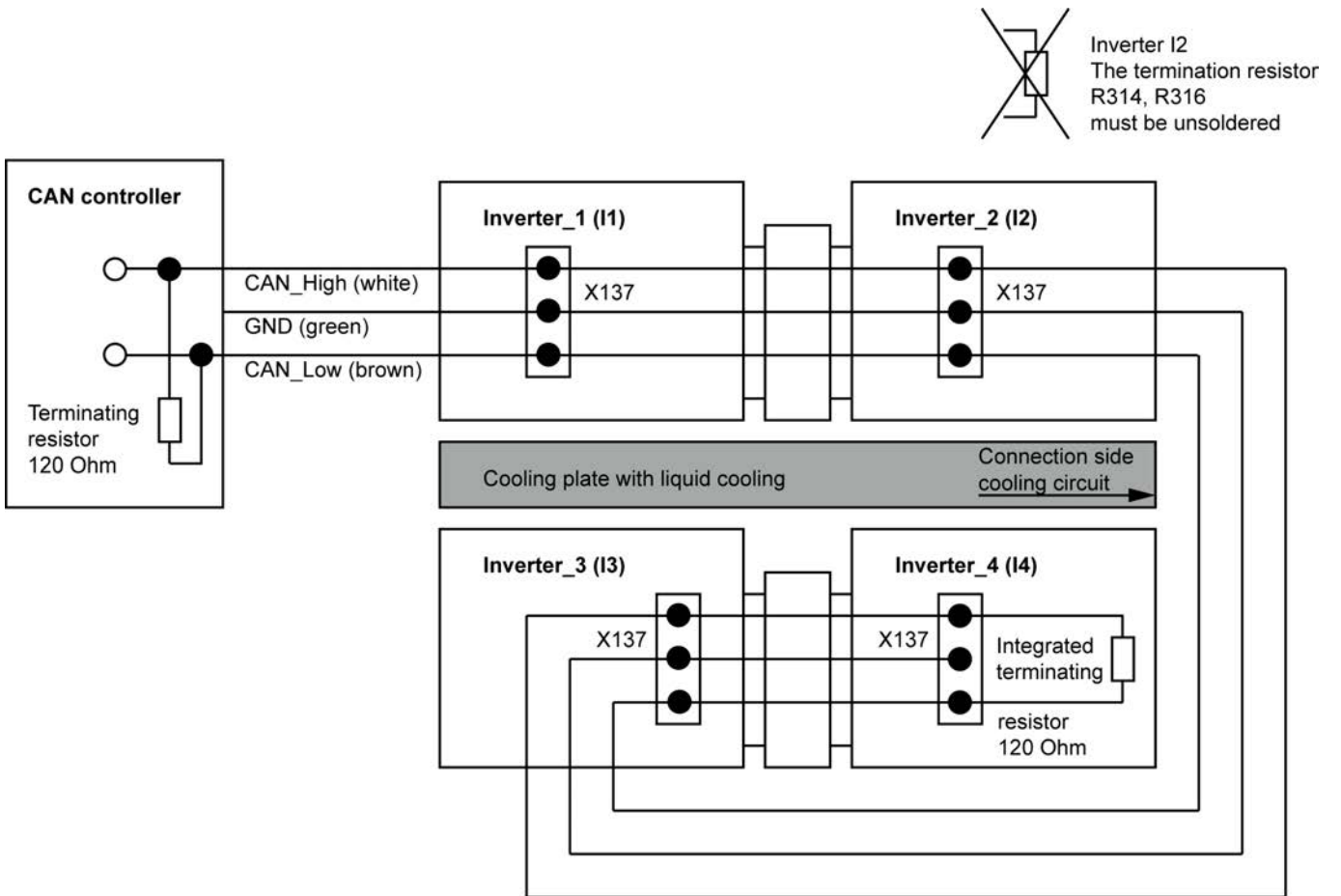

Position of the terminating resistors on the controller card.
 The terminating resistors are unsoldered on the images.

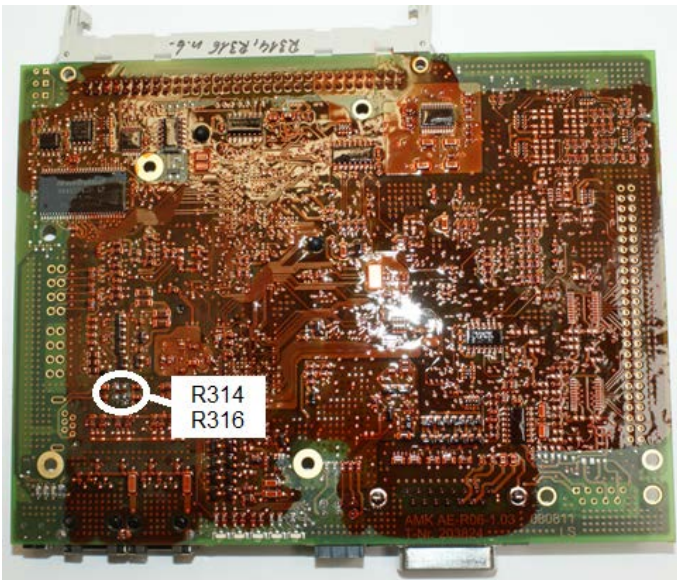

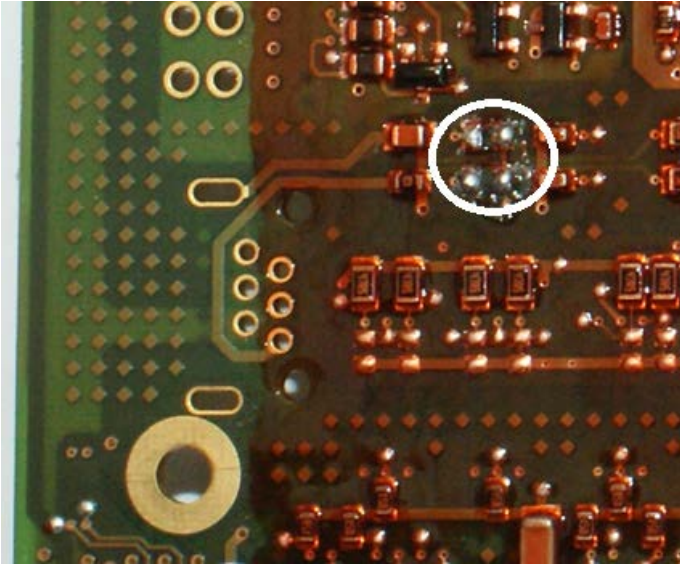

Position of the CAN interface X137 on the controller card.

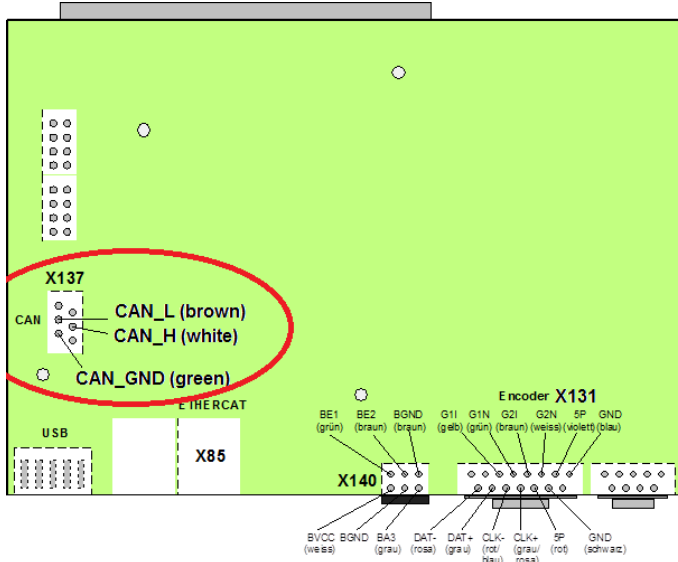

8.1.3 Data telegrams

The data telegrams are each 8 bytes long and are transmitted in Intel format.

Messages from the AMK inverter to the CAN controller are sent based on the time specified in ID34028 'BUS output rate'. The default value is 5 ms. The 'BUS output rate' can be adjusted in 1 ms increments.

Messages sent from the CAN controller to the AMK inverter are retrieved by the inverter in a 1 ms cycle.



Telegram failure monitoring:

The telegram failure monitoring is activated with the first received data message. Following the data telegrams must be transmitted cyclically.

The telegram failure monitoring function responds if the inverter has not received a telegram from the CAN controller for more than 50 ms.

In this case, the inverter generates an error message and the motor coasts down (setpoint 0 %M_N).

The different inverters (node addresses) are addressed with the aid of the base address + offset (corresponding ID34023 'BUS address participant').

Example:

Calculating the CAN identifier (COB-ID) for AMK Actual Values 1 from the inverter with node address 2
 $0x282$ (AMK actual values 1) + $0x2$ (node address) = $0x284$ (CAN identifier)



The ID34023 'BUS address participants' must be selected so that multiple identical COB-IDs cannot occur in the same CAN bus system.

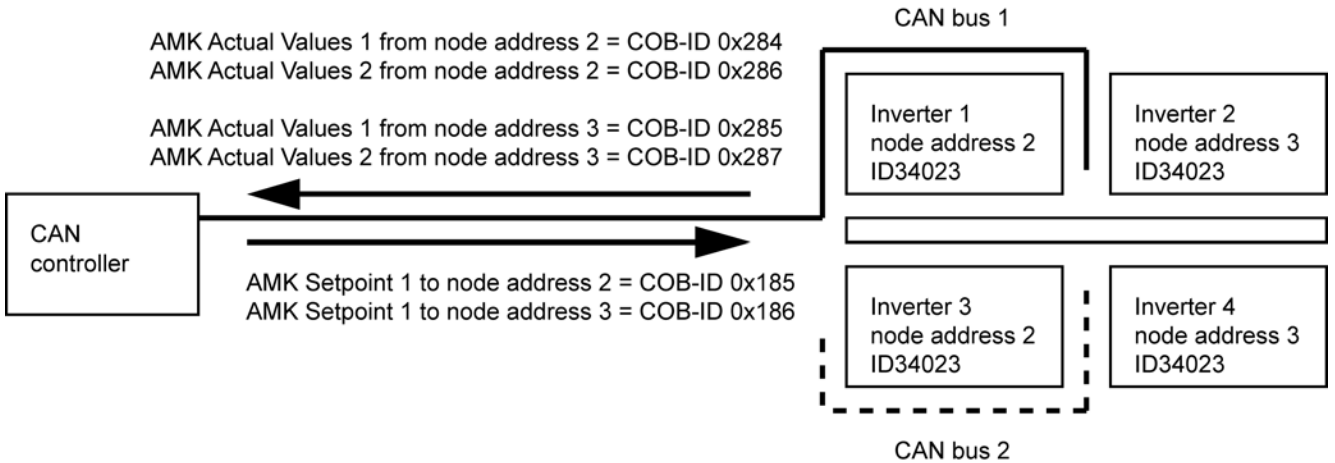

Inverter CAN configuration: [See 'CAN bus communication parameters' on page 34.](#)

Description of the data telegrams

The following data telegrams are available for exchanging data between the inverter and CAN controller:

Base address	Name	Direction	Meaning
0x282	AMK Actual Values 1	Inverter → CAN controller	Contains the status word and actual values
0x284	AMK Actual Values 2	Inverter → CAN controller	Contains actual values
0x183	AMK Setpoints 1	CAN controller → inverter	Contains the status word and setpoints

Content of the 'AMK Actual Values 1' data telegram:

Name	Offset	Length in bits	Value type	Unit	Meaning
AMK_Status	0	16	Unsigned	-	Status word See the table below: Content of the 'AMK_Status' status word
AMK_ActualVelocity	16	16	Signed	rpm	Actual speed value
AMK_TorqueCurrent	32	16	Signed	-	Raw data for calculating 'actual torque current' Iq See 'Units' on page 65.
AMK_MagnetizingCurrent	48	16	Signed	-	Raw data for calculating 'actual magnetizing current' Id See 'Units' on page 1.

Content of the 'AMK_Status' status word

The system status and the command acknowledgments are displayed via the status word.

Name	Offset	Length in bits	Meaning
AMK_bReserve	0	8	Reserved
AMK_bSystemReady	8	1	System ready (SBM)
AMK_bError	9	1	Error
AMK_bWarn	10	1	Warning
AMK_bQuitDcOn	11	1	HV activation acknowledgment
AMK_bDcOn	12	1	HV activation level
AMK_bQuitInverterOn	13	1	Controller enable acknowledgment
AMK_bInverterOn	14	1	Controller enable level
AMK_bDerating	15	1	Derating (torque limitation active)

Content of the 'AMK Actual Values 2' data telegram:

Name	Offset	Length in bits	Value type	Unit	Meaning
AMK_TempMotor	0	16	Signed	0.1 °C	Motor temperature
AMK_TempInverter	16	16	Signed	0.1 °C	Cold plate temperature
AMK_ErrorInfo	32	16	Unsigned	-	Diagnostic number
AMK_TempIGBT	48	16	Signed	0.1 °C	IGBT temperature

Content of the 'AMK Setpoints 1' data telegram:

Name	Offset	Length in bits	Value type	Unit	Meaning
AMK_Control	0	16	Unsigned	-	Control word See the table below: Content of the 'AMK_Control' control word
AMK_TargetVelocity	16	16	Signed	rpm	Speed setpoint
AMK_TorqueLimitPositiv	32	16	Signed	0.1% M _N	Positive torque limit (subject to nominal torque)
AMK_TorqueLimitNegativ	48	16	Signed	0.1% M _N	Negative torque limit (subject to nominal torque)

Content of the 'AMK_Control' control word

The control word can be used to trigger the following commands in the inverter:

Name	Offset	Length in bits	Meaning
AMK_bReserve	0	8	Reserved
AMK_bInverterOn	8	1	Controller enable
AMK_bDcOn	9	1	HV activation
AMK_bEnable	10	1	Driver enable
AMK_bErrorReset	11	1	Remove error*
AMK_bReserve	12	4	Reserved

*Setpoints must have the value 0, as otherwise the 'Remove error' command will not be executed.

8.1.4 Diagnostic message 3586 (CAN error)



The AMK AIPEX PRO software displays the additional information (Info 1 and Info 2) in decimal format. One piece of additional information can contain several diagnostic messages. For the purposes of evaluation, this value must be converted to a binary value.

Example:

AIPEX PRO diagnosis in 'dec' Info 1 = 12

Converted to 'bin': Info 1 = 01100

Corresponds to the message: Invalid value for bus output rate and invalid value for bus transmission rate

<ul style="list-style-type: none"> Diagnostic message 3586 (CAN error) 																							
Device	FSE inverter																						
Description	Errors that occur when initializing the CAN are declared with 'Additional info 1'. Errors that occur when operating the CAN are declared with 'Additional info 2'.																						
Category	Error																						
Drive behavior	System failure or drive coasts down																						
Device behavior																							
Additional information (AMK Service information)																							
	Info 1	Decimal	Bit																				
		0	0																				
			- (error during operation)																				
			<table border="1"> <thead> <tr> <th>Info 2</th> <th>Decimal</th> <th>Bit</th> <th></th> </tr> </thead> <tbody> <tr> <td>1</td> <td>0</td> <td></td> <td>Failure of setpoint message for > 50 ms</td> </tr> <tr> <td>16</td> <td>4</td> <td></td> <td>Unknown message received</td> </tr> <tr> <td>32</td> <td>5</td> <td></td> <td>Message with incorrect length received</td> </tr> <tr> <td>64</td> <td>6</td> <td></td> <td>Error while sending</td> </tr> </tbody> </table>	Info 2	Decimal	Bit		1	0		Failure of setpoint message for > 50 ms	16	4		Unknown message received	32	5		Message with incorrect length received	64	6		Error while sending
Info 2	Decimal	Bit																					
1	0		Failure of setpoint message for > 50 ms																				
16	4		Unknown message received																				
32	5		Message with incorrect length received																				
64	6		Error while sending																				
		1	0																				
		2	1																				
		4	2																				
		8	3																				
		16	4																				
			Error while saving																				
			Module job error																				
			Invalid value for bus output rate																				
			Invalid value for bus transmission rate																				
			Error while accessing CAN																				

8.2 FSE firmware functional description

The torque at the servo motor is controlled subject to the setpoint (accelerator position). The setpoint for the inverters is specified via a higher-level CAN controller. The inverters operate the servo motors in the speed control operating mode. In contrast to the torque control operating mode, the advantage of this mode is that the motor speed can be limited dynamically in addition to the limitation of the torque.

8.2.1 Controller structure

Simplified diagram of the controller structure:

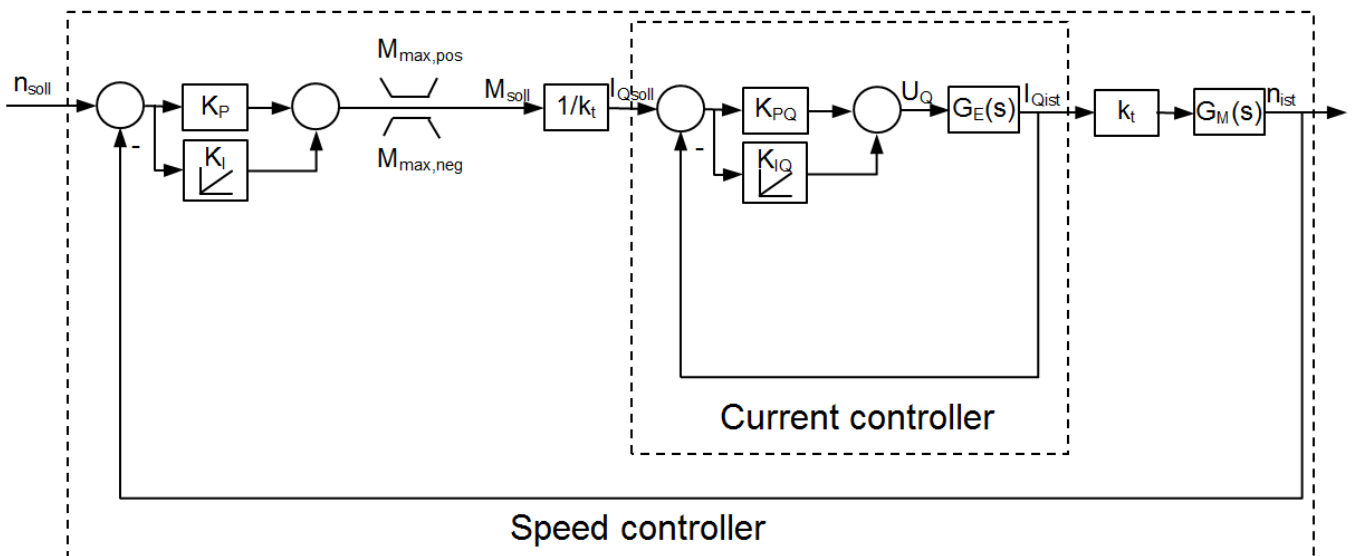

Label	Description	CAN variable
n setpoint	Speed setpoint	AMK_TargetVelocity
n _{actual}	Actual speed value	AMK_ActualVelocity
M _{max, pos}	Positive torque limit	AMK_TorqueLimitPositiv
M _{max, neg}	Negative torque limit	AMK_TorqueLimitNegativ
K _P	Speed controller gain (P value) (ID100 'Speed control proportional gain KP')	-
K _I	Speed controller integration constant (I value) (as reset time T _n in ID101 'Integral-action time speed control TN')	-
M _{soll}	Torque setpoint	-
kt	Motor torque constant (ID32771 'Nominal torque'/ ID111 'Motor nominal current IN')	-
K _{PQ}	Current controller gain (P value) (ID34151 'Current path Q proportional gain KP')	-
K _{IQ}	Current controller integration constant (I value) (as reset time T _n in D34050 'Current path Q integral-action time TN')	-
G _E (S)	Transmission function for electrical controlled system	-
G _M (S)	Transmission function for mechanical controlled system	-

8.2.2 Driving modes

NOTE	
Material damage!	<p>Destruction of the battery! Impermissible charging and discharging currents will destroy the battery.</p> <p>Preventive measures: When defining the acceleration and braking torque, it must be ensured that the permissible charging and discharging currents of the battery are observed.</p>

Driving mode	Description	CAN Variable
Forward acceleration	Speed setpoint = required positive speed [1/min]	AMK_TargetVelocity
	Positive torque limitation = required positive acceleration torque [0,1 %M _N]	AMK_TorqueLimitPositiv
	Negative torque limit = (negative sign) required negative deceleration torque [0,1 %M _N] ¹⁾	AMK_TorqueLimitNegativ
Coasting	Speed setpoint = any speed [1/min]	AMK_TargetVelocity
	Positive torque limitation = 0 [0,1 %M _N]	AMK_TorqueLimitPositiv
	Negative torque limitation = 0 [0,1 %M _N]	AMK_TorqueLimitNegativ
Brakes on 0 1/min with positive speed value	Speed setpoint = 0 [1/min]	AMK_TargetVelocity
	Positive torque limitation = 0 [0,1 %M _N]	AMK_TorqueLimitPositiv
	Negative torque limitation = (negative sign) required negative deceleration torque [0,1 %M _N]	AMK_TorqueLimitNegativ
Brakes on 0 1/min with negative speed value	Speed setpoint = 0 [1/min]	AMK_TargetVelocity
	Positive torque limitation = required positive deceleration torque [0,1 %M _N]	AMK_TorqueLimitPositiv
	Negative torque limitation = 0 [0,1 %M _N]	AMK_TorqueLimitNegativ
Reverse acceleration	Speed setpoint = (negative sign) required speed [1/min]	AMK_TargetVelocity
	Positive torque limitation = any [0,1 %M _N]	AMK_TorqueLimitPositiv
	Negative torque limitation = (negative sign) acceleration torque [0,1 %M _N]	AMK_TorqueLimitNegativ

- 1) Exceeds the actual speed the speed setpoint, for example when driving downhill the motor brakes with the given deceleration torque.

8.2.3 FSE diagnostic message

• Diagnostic message 3585 for FSE inverter																				
Device	FSE inverter																			
Description	Specific diagnostic messages for the FSE firmware																			
Category	Error																			
Drive behavior	Drive coasts down																			
Device behavior																				
Additional information (AMK Service information)																				
	Info 1	1	-																	
			Info 2	3	<table border="1"> <tr> <td>Info 3</td> <td>1</td> <td>Upper voltage limit ID32798-3 < lower voltage limit ID32798-4</td> </tr> <tr> <td>Info 3</td> <td>4</td> <td>Sign error with torque limits from calculation</td> </tr> <tr> <td>Info 3</td> <td>5</td> <td>0 V > intermediate circuit voltage or intermediate circuit voltage > 1,000 V</td> </tr> <tr> <td>Info 3</td> <td>7</td> <td>Error defining quadrants</td> </tr> <tr> <td>Info 3</td> <td>8</td> <td>Incorrect settings, voltage limitation ID32798-3 < ID32798-7 or ID32798-4 > ID32798-10</td> </tr> </table>	Info 3	1	Upper voltage limit ID32798-3 < lower voltage limit ID32798-4	Info 3	4	Sign error with torque limits from calculation	Info 3	5	0 V > intermediate circuit voltage or intermediate circuit voltage > 1,000 V	Info 3	7	Error defining quadrants	Info 3	8	Incorrect settings, voltage limitation ID32798-3 < ID32798-7 or ID32798-4 > ID32798-10
Info 3	1	Upper voltage limit ID32798-3 < lower voltage limit ID32798-4																		
Info 3	4	Sign error with torque limits from calculation																		
Info 3	5	0 V > intermediate circuit voltage or intermediate circuit voltage > 1,000 V																		
Info 3	7	Error defining quadrants																		
Info 3	8	Incorrect settings, voltage limitation ID32798-3 < ID32798-7 or ID32798-4 > ID32798-10																		
		2	Info 2	1	Info 3 0 I ² t / temperature derating settings															
		5	Info 2	1	Info 3 0 Error with asynchronous data storage															

8.2.4 Units

Torque

All system torque values refer to ID32771 'Nominal torque' and are specified to 0.1 % M_N of its value. Please refer to the type plate or data sheet for the motor for the parameter value. The key reference for the torque data is ID111 'Motor nominal current I_N'.

Speed

All speed values are specified in rpm.

Temperature

All temperature values are specified to 0.1 °C.

Id and Iq

The currents are related to the device-specific value in ID110 'Converter peak current'. The actual current in A is calculated as follows:

$$I_q = \frac{AMK_TorqueCurrent * ID110}{16384}$$

$$I_d = \frac{AMK_MagnetizingCurrent * ID110}{16384}$$

Transmission rate

N... Number of messages

X... Number of devices in the network

$$X = \frac{ID34028[s] * ID34024[bit / s]}{111[bit] * N}$$

8.2.5 Drive behavior in the event of an error

In the event of an error, a CAN error message 'AMK_ErrorInfo' is generated by the inverter and the 'AMK_bError' CAN error bit is set. Depending on the cause of the error, the motor will be switched to torque-free operation or the trigger signals for activating the power output stages will be blocked at two channels (identical to X15 EF / EF2 = 0).

Torque-free means that motor control continues to be active at a speed setpoint of 0% M_N . The motor behaves in the same way as it does when coasting down. If $N_{act} = 0$ rpm, motor control is deactivated and the 'AMK_bQuitInverterOn' CAN status signal is reset.

Power output stage activation blocked means that motor control is deactivated and the 'AMK_bQuitInverterOn' CAN status signal is reset. Providing that the axis is rotating, the rotor's permanent magnets induce an inverse voltage at the motor connections of the inverter. The behavior of the motor (coasting / braking) depends on whether the induced voltage is > DC link (HV voltage). In this case, the circuit closes via the free-wheeling diodes in the power transistor and braking occurs (DC braking). The braking torque is subject to the actual speed value. If the induced voltage decreases to < DC link (HV voltage), the motor coasts down.

The induced inverse voltage in the DC link (HV voltage) is calculated using the following formula and must not be more than 800 VDC:

ID34234 'Voltage constant K_e ' x actual speed value x $\sqrt{2} / 1,000$



To ensure that the motor is reliably disconnected, a suitable disconnecter must be installed.

Overview of drive behavior in the event of an error / when resetting EF / EF2:

Situation	EF / EF2 (X15)	AMK_bError (CAN)	AMK_bQuitInverterOn (CAN)	Induced voltage > HV voltage	Behavior
1	1	1	1	No	Motor control: active Torque setpoint: 0% M_N Motor behavior: coasts down
2	1	1	1	Yes	Motor control: active Torque setpoint: 0% M_N Motor behavior: coasts down
3	1	1	0	No	Motor control: deactivated ¹⁾ Torque setpoint: - Motor behavior: coasts down (behavior identical to situation 5)
4	1	1	0	Yes	Motor control: deactivated ¹⁾ Torque setpoint: - Motor behavior: generator (recuperative) operation (behavior identical to situation 6)
5	0	1	0	No	Motor control: deactivated ¹⁾ Torque setpoint: - Motor behavior: coasts down
6	0	1	0	Yes	Motor control: deactivated ¹⁾ Torque setpoint: - Motor behavior: generator (recuperative) operation

1) The trigger signals for activating the power output stages are blocked at two channels.



It is only ever the drive system of the inverter that generates the error that is switched to torque-free operation; the other drive systems continue to be controlled as normal.

The program for the higher-level CAN controller must be designed so that errors are detected and the other drive systems are switched off based on the current situation.

8.2.6 Diagram for error scenarios

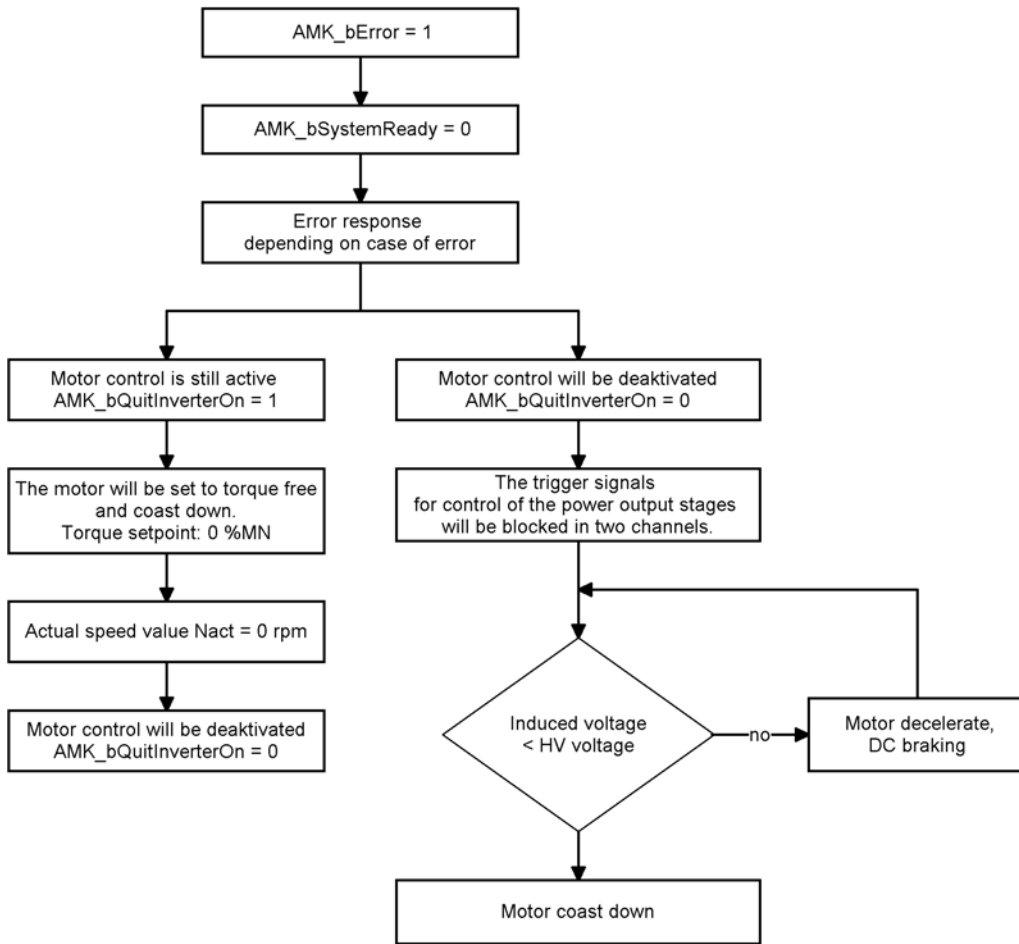

8.2.7 'Remove error' diagram

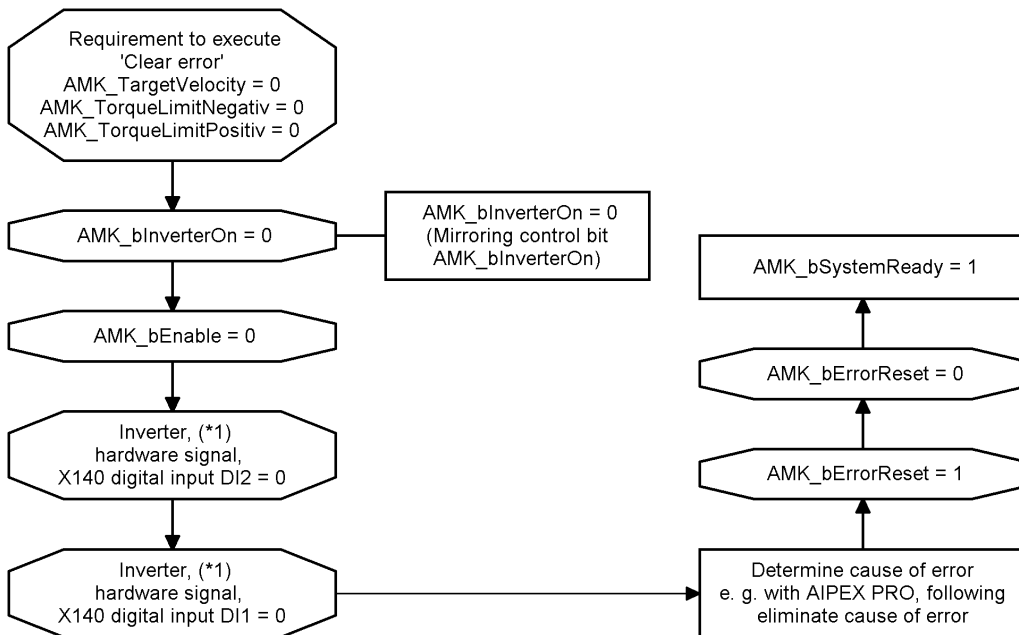

1) Optional

8.2.8 Torque limitation

Operating the motor with torque levels above the nominal torque is permitted within clearly defined limits. If the limits are exceeded, the drive generates a diagnostic message. The power output stage is switched off and the motor coasts down. To enable the inverter to be operated in a fault-free manner, even at maximum load, the maximum motor torque is reduced automatically.

Derating is based on the following measured variables:

- Motor temperature
- Inverter power supply (IGBT) temperature
- Inverter cold plate temperature
- Overload as per inverter current integral
- Overload as per motor current integral
- Undervoltage or overvoltage in the HV circuit

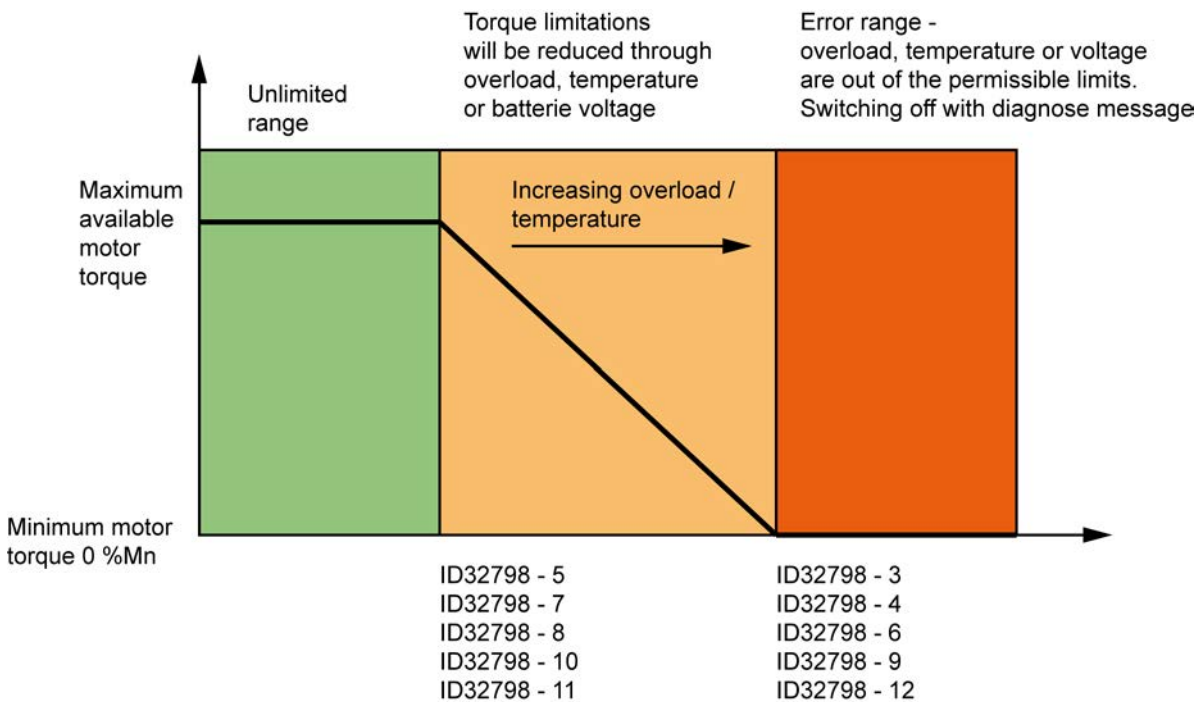

Derating calculates a limit for the torque current. To ensure that this limit is not exceeded, the torque limits are influenced. Only the positive or negative torque limit that is currently active during operation is influenced.

No error messages are issued when the voltage limits are exceeded. However, torque cannot be taken from the motor that would cause the limits to be exceeded further.

If power is being reduced, this is signaled via the CAN bus with the 'AMK_bDerating' CAN variable.

Configuring torque limitation:

Temperature Motor	Temperature measured by KTY in the motor winding, connected to terminal X12 at the inverter	
	ID32798 'User list 1'	
	ID32798 - 11	Motor temperature at which full torque is available
	ID32798 - 12	Motor temperature at which no torque is available
Temperature Inverter power supply (IGBT)	Temperature measured (IGBT) by temperature model	
	ID32798 'User list 1'	
	ID32798 - 8	Power supply temperature at which full torque is available
	ID32798 - 9	Power supply temperature at which no torque is available

Temperature Inverter cold plate	Temperature measured by KTY on cold plate	
	ID32798 'User list 1'	
	ID32798 - 5	Inverter temperature at which full torque is available
	ID32798 - 6	Inverter temperature at which no torque is available
Overload as per inverter current integral	Always active, cannot be deactivated	
	ID32999 'Overload limit inverter' Threshold of the inverter current integral from which derating starts and a message is issued	
Overload as per motor current integral 1)	Activate the I ² t monitoring of the servo motor in ID32773 'Service bits', bit 14	
	ID114 'Overload limit motor' Threshold of the motor current integral from which derating starts and a message is issued.	
	Relevant motor parameters ID109 'Motor peak current' ID34096 'Standstill current motor' ID34168 'Time maximum current motor'	
Undervoltage or overvoltage in the HV circuit	ID32798 'User list 1'	
	ID32798 - 3	Maximum battery voltage (end-of-charge voltage)
	ID32798 - 4	Minimum battery voltage (deep discharge)
	ID32798 - 7	Start of reduction for end-of-charge voltage
	ID32798 - 10	Start of reduction for deep discharge protection



1) The magnetizing current is not taken into account in the calculation. If high speeds occur in the field weakening range, this can lead to increased heating in the motor.



Configuration information: [See 'FSE parameters' on page 35.](#)

8.2.9 Battery protection

Basic battery protection that can prevent overvoltage and undervoltage in the battery is integrated in the FSE firmware.

If the battery voltage is between ID32798 - 7 and ID32798 - 3, the generator torque limit (the positive or negative torque limit depending on the current direction of rotation) is reduced linearly so that the end-of-charge voltage in ID32798 - 3 cannot be exceeded. If the battery voltage is between ID32798 - 10 and ID32798 - 4, the motor torque limit is reduced linearly so that it is not possible to fall below the deep discharge threshold in ID32798 - 4.



External battery monitoring must be used to evaluate the charging states of the individual battery cells.

8.3 Motor encoders

Inductive motor encoders are integrated into the DYNASYN DD5-14-10-POW-18600-B5 synchronous servo motors (AMK classification P). They are single-turn absolute encoders with a digital EnDat 2.2 light interface.

The main job of the motor encoder is to feed back the position of the rotor to the inverter. With field-based regulation, the current setpoints and current commutations are calculated from the rotor position. The synchronous motor requires an absolute measuring system that is aligned with the poles of the permanent magnets in the rotor. The evaluation electronics use the encoder signals to generate the actual speed value for the drive control.



To ensure correct commutation for synchronous motors, the encoder must be adjusted after it has been mounted on the motor shaft. The encoder adjustment function is started with a command (ID32843 'Service command'). The commutation offset defined during the encoder adjustment is stored in the encoder if it has an encoder store. If the position of the encoder changes in relation to the motor shaft (e.g., if the encoder is replaced), the commutation offset must be redefined, as otherwise it will not be possible to control the motor. AMK motors with absolute encoders and encoder stores are adjusted at the factory and delivered with a valid commutation offset.

9 Startup

9.1 Wiring the motor and supply cables

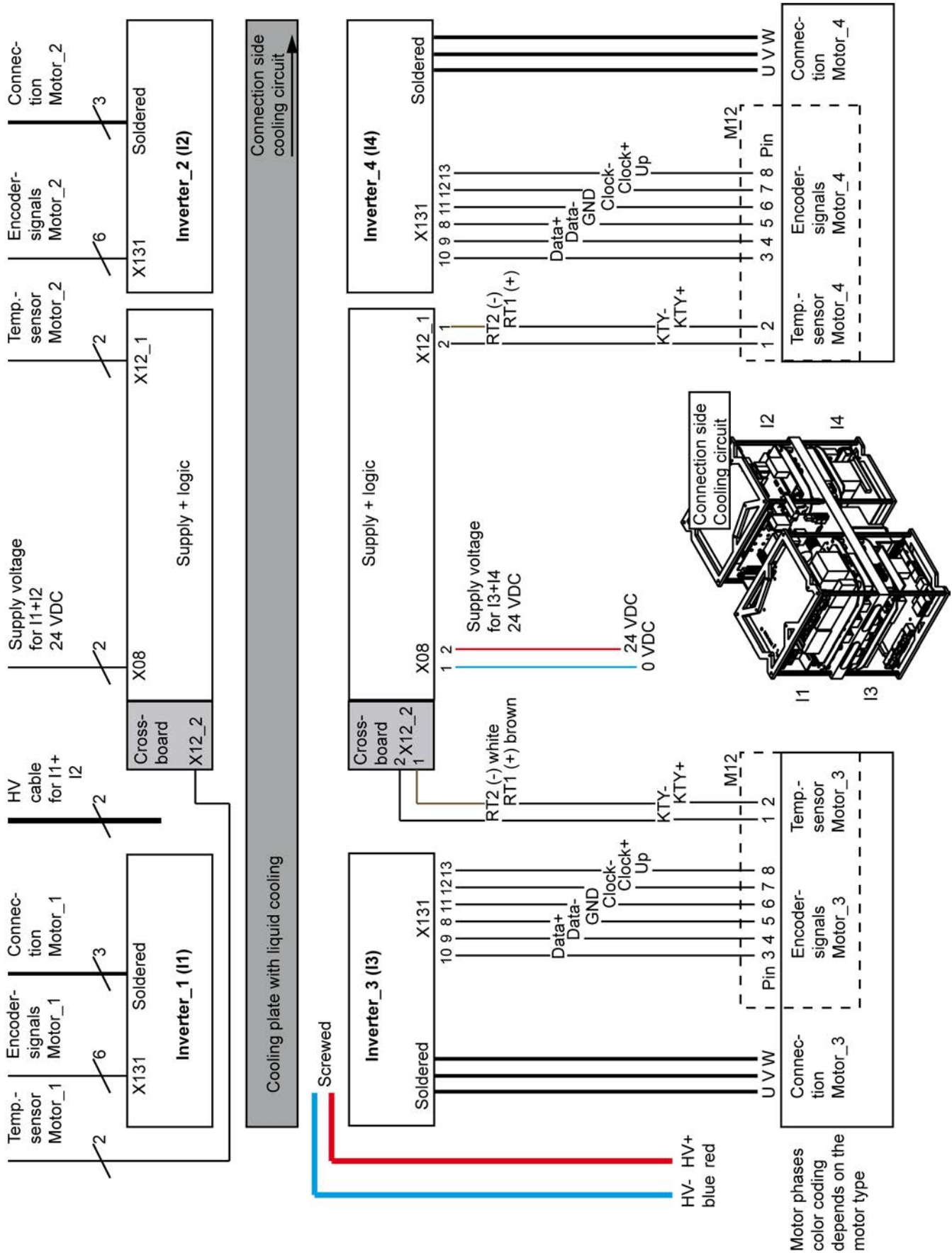

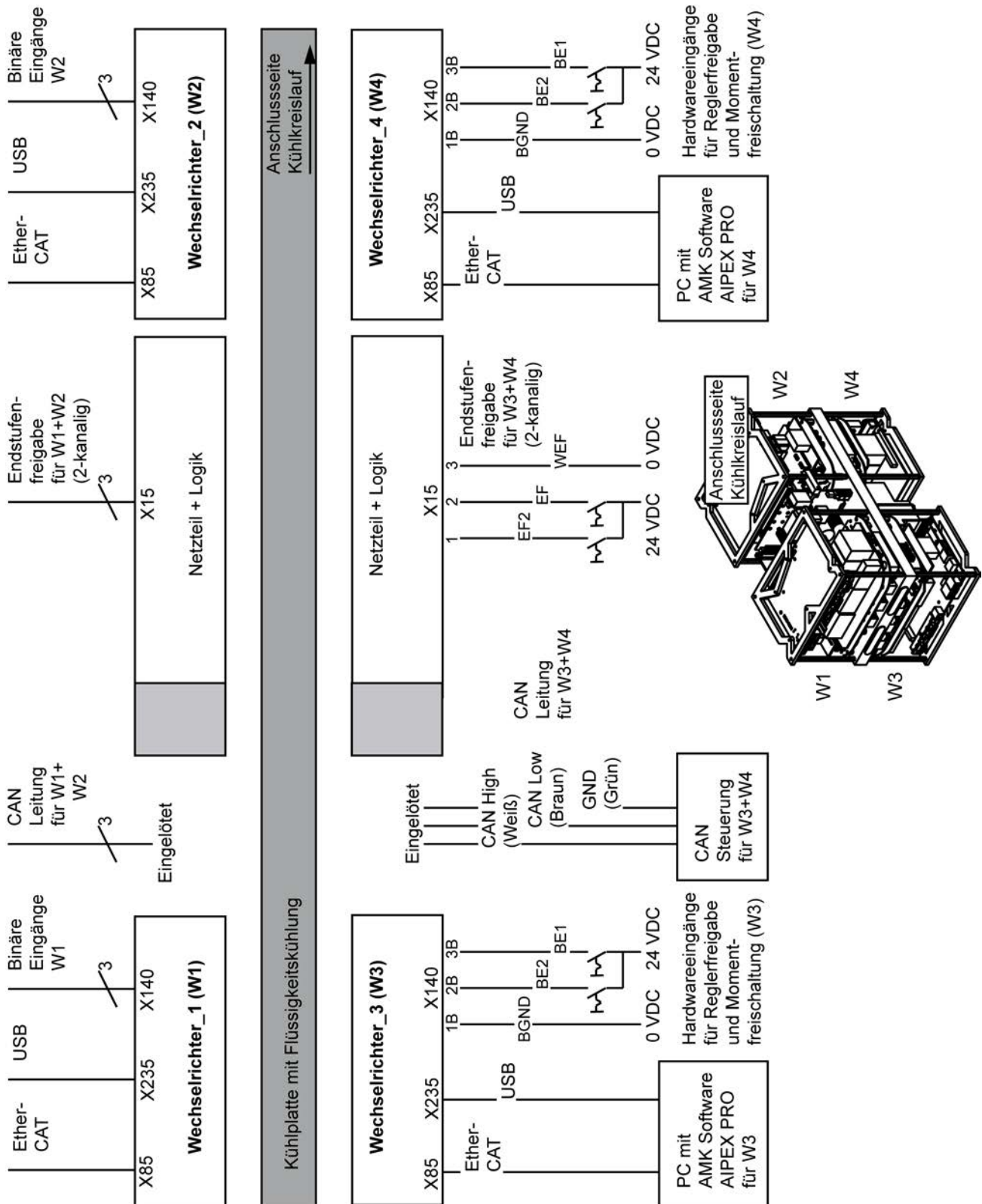

9.2 Wiring the interface and control cables



9.3 Startup with AIPEX PRO

Prior to startup, please read the following chapters in the Software description AIPEX PRO V3:

- AIPEX PRO → Program overview
- AIPEX PRO → Tabs
- AIPEX PRO → Menu bar

Step	To do	Detailed description
1	<p>Install AIPEX PRO on a PC with a Windows operating system and Ethernet and / or USB interface.</p>  <p>Components required</p> <ul style="list-style-type: none"> • AIPEX: startup and parameter explorer • ATF: firmware update tool • USBCOM: driver for serial communication via USB • WinPcap: Windows packet capture library for access to EtherCAT 	<p>Software description AIPEX PRO V3 chapter: AIPEX PRO → Installation instructions</p>
2	<p>EtherCAT connection (recommended) Connect the PC's Ethernet connection to the X85 interface on the inverter.</p>  <p>EtherCAT must be activated in the AIPEX PRO communication settings.</p> <p>Alternative: USB connection Connect the PC's USB connection to the X235 interface on the inverter. (No other communication settings required)</p>	<p>Software description AIPEX PRO V3 chapter: AIPEX PRO → Communication between PC and AMK device → EtherCAT interface</p>
3	<p>Communication testing (EtherCAT connection)</p> <ul style="list-style-type: none"> • Apply the 24 VDC supply voltage to inverter terminal X08 • Launch AIPEX PRO • Following the initialization phase, the green 'communication icon' on the PC status bar indicates that there is an active connection between the PC (with AIPEX PRO) and the inverter. 	<p>Software description AIPEX PRO V3 chapter: AIPEX PRO → Communication between PC and AMK device → Testing communication</p>
4	<p>The following AIPEX PRO functions are required for startup, maintenance, service, etc. Test the functions.</p> <ul style="list-style-type: none"> • Log in • Read and save the device data • Load an offline project on a device • Perform diagnosis with AIPEX PRO • Test generator • Configure oscilloscope 	<p>Software description AIPEX PRO V3 chapter: AIPEX PRO → Functions</p>
5	<p>Configure the inverter. The relevant parameters can be found in the Planning chapter:</p> <ul style="list-style-type: none"> • See 'Configuration' on page 33. • See 'Motor parameters' on page 34. • See 'CAN bus communication parameters' on page 34. • See 'FSE parameters' on page 35. • See 'Default parameters' on page 36. • See 'Direction of rotation for motor shaft' on page 37.  <p>The modified parameters values are only activated once the system has been restarted.</p> <p>24 VDC OFF / ON (terminal X08)</p>	<p>Software description AIPEX PRO V3 chapter: AIPEX PRO → Tabs → Parameters</p>
6	<p>Activate motor control.</p>	<p>See 'On and off diagram' on page 75.</p>
7	<p>Optimize the speed control circuit, if necessary.</p>	<p>See 'Tuning the speed controller' on page 76.</p>
8	<p>Test the specified setpoint via CAN bus.</p>	<p>See 'Driving modes' on page 64.</p>

9.4 On and off diagram

The supply and hardware inputs are supplied, set, and reset via the terminals (Xxxx) at the inverters. The status and control signals (AMK_xxx) are read, set, and reset via a higher-level CAN controller.



The control signals must be sent cyclically at < 50 ms, as otherwise the telegram failure monitoring function will respond.

Each inverter must be activated separately.

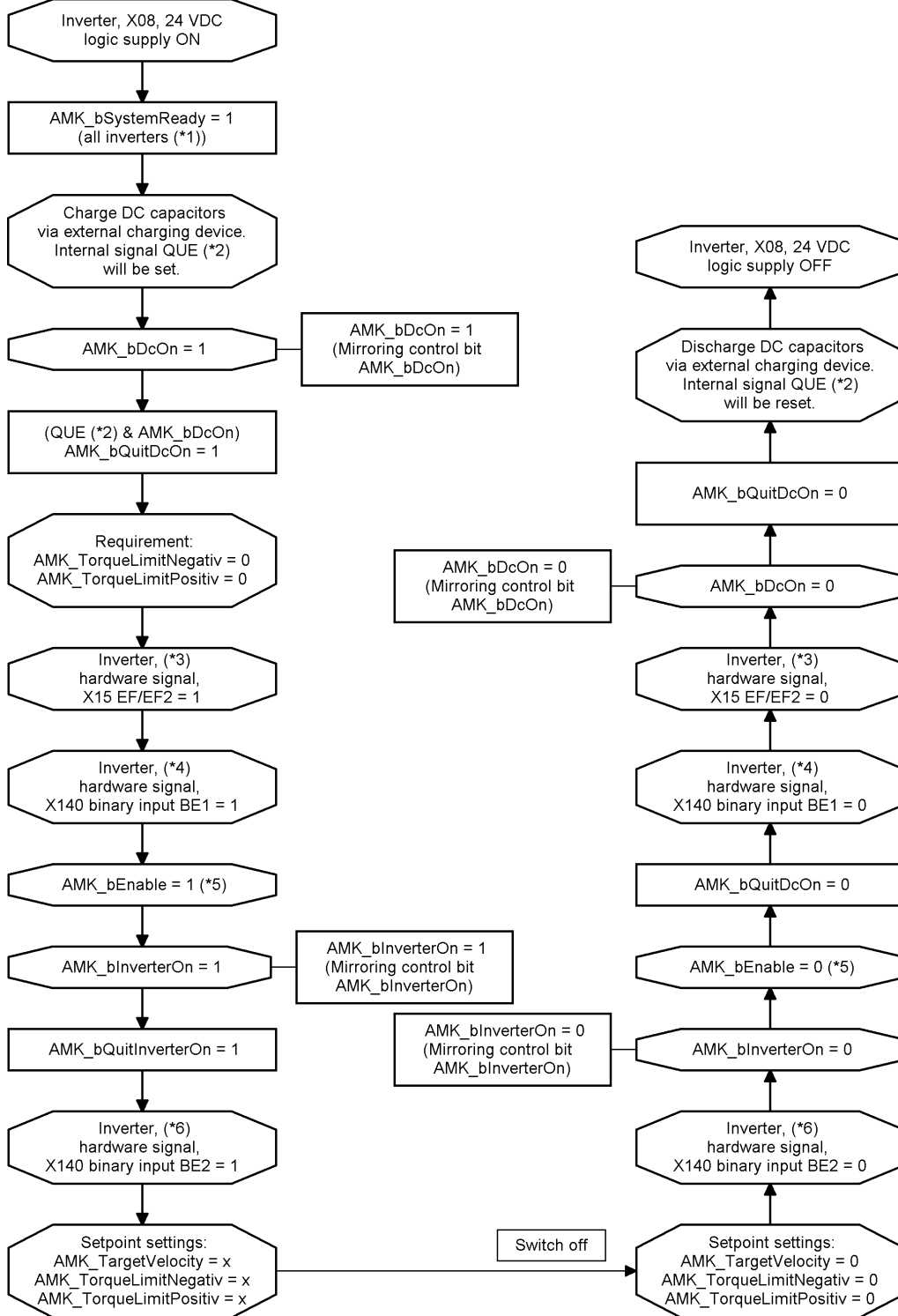

(*1) Each inverter delivers an 'AMK_bSystemReady' status signal (AMK SBM signal). All status signals have to be evaluated in a higher-level CAN controller.

(*2) The internal QUE status signal is set as soon as the HV DC voltage > ID32837 'DC bus voltage monitoring'.

(*3) The EF / EF2 output stage enable may only be removed when the RF controller enable is switched off and when the motor is at a standstill. Switching off EF / EF2 during operation will generate an error message in the drive and the motor will coast down.

Interrupting the EF / EF2 control inputs blocks the trigger signals for activating the power output stages at two channels. The motor is then in a torque-free state but the drive system is not completely disconnected. If, in the event of an interruption, the motor speed is in the field weakening range, this can cause the motor to be braked. See ['Drive behavior in the event of an error' on page 66](#).

The power output stage is unblocked by setting the EF and EF2 signals.

Following the enable, the drive can be supplied with power by setting the RF controller enable (X140 BE1 = 1, 'AMK_bEnable' = 1, 'AMK_bInverterOn' = 1).



If the function is not used, the EF / EF2 control inputs can be permanently connected to 24 VDC.

(*4) Activating the controller enable also requires the hardware input BE1 to be set in addition to the CAN signals ('AMK_bInverterOn' and 'AMK_bEnable'). BE1 is similar to the terminal designation X15 (ignition key) in the automotive sector.

BE1 = 1 : controller enable RF possible

BE1 = 0 : controller enable RF blocked



If the function is not used, the BE1 hardware input can be permanently connected to 24 VDC.

(*5) The 'AMK_bEnable' control signal must be set and reset, but does not activate any function.

(*6) Activating the predefined torque limits requires the BE2 hardware input to be set.

BE2 = 1 : torque limits active

BE2 = 0 : torque limits deactivated, motor without torque



If the function is not used, the BE2 hardware input can be permanently connected to 24 VDC.

9.5 Optimizing the current controller

With AMK synchronous servo motors, the current control parameters defined by AMK are transferred from the motor data sheet to the inverter via the motor database integrated in AIPEX PRO.

9.6 Tuning the speed controller

By means of the AIPEX PRO startup function, a square wave speed setpoint step-change is preset. The step response is recorded with the AIPEX PRO oscilloscope.

The controller parameters ID100 'Speed control proportional gain KP', ID101 'Integral-action time speed control TN' und ID102 'Differentiating time speed control TD' are displayed and tuned in the temporary parameter list and therefore are directly valid in the drive.

This chapter describes how to tune the speed controller by means of AIPEX PRO.

The Function description (AMK part no. 203878), chapter 'Setting the control loop', describes the general procedure of tuning the speed controller.

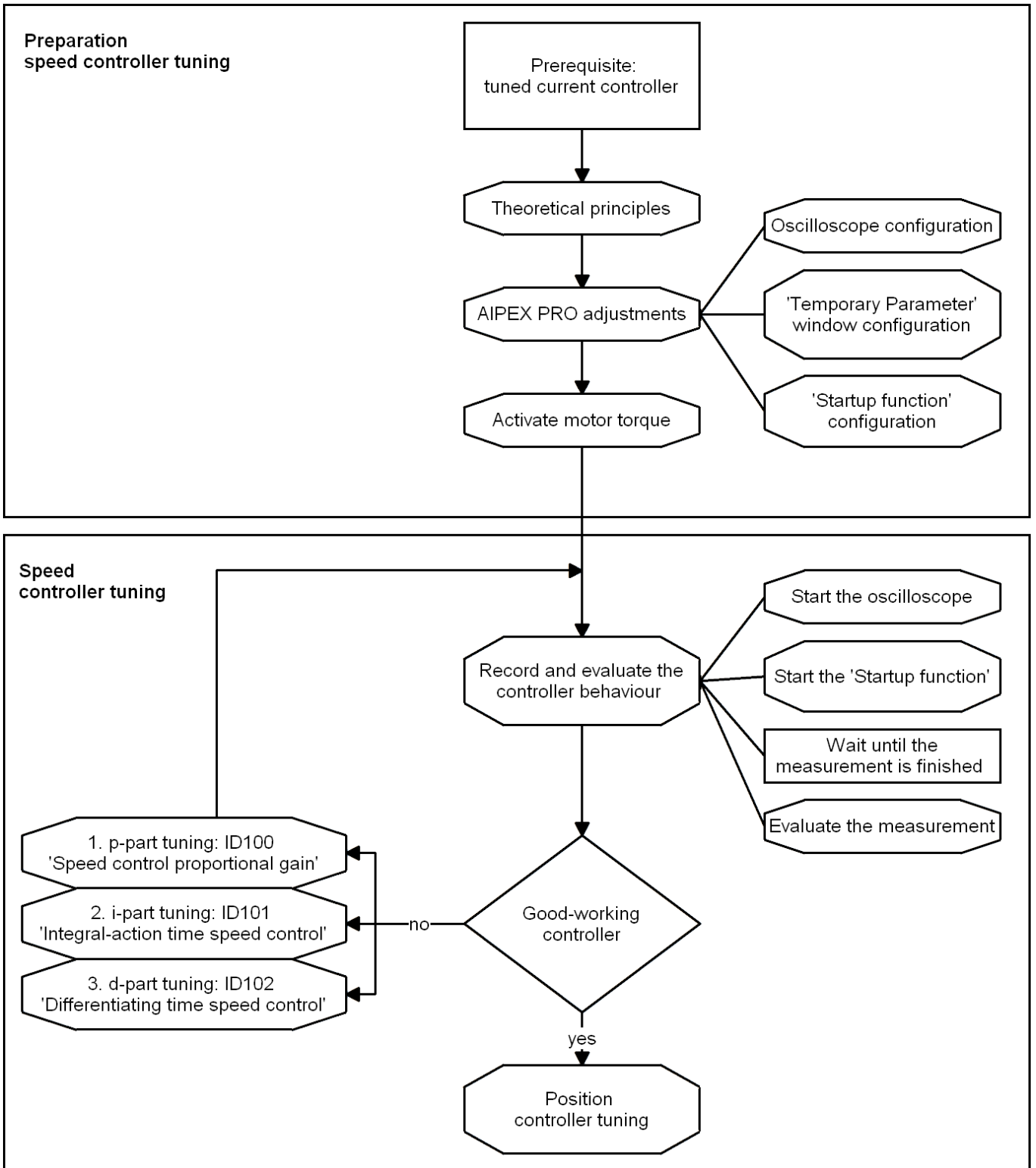

9.6.1 Theoretical basis

The PID speed controller needs to be set and optimised depending on the application.

The precise mathematical description of all parameters of the control circuit has been shown often to be rather extensive and difficult in practical applications. Therefore, a simple procedure shall be presented here by which the controller can be set practically.

For that, a speed step-change (without ramp) needs to be given as a reference variable at the input of the controller. The step response (speed actual value) should be recorded for evaluating the controller setting. When specifying the speed step, make sure that the drive remains operating below the torque limit.

Set the controller as follows:

1. Setting ID100 'Speed control proportional gain KP' K_p , with ID101 = 0 (T_n), ID102 = 0 (T_d)
2. Setting ID101 'Integral-action time speed control TN' T_n , with ID100 = const. (K_p), ID102 = 0 (T_d)
3. Setting ID102 'Differentiating time speed control TD' T_d , with ID100 = const. (K_p), ID101 = const. (T_n)

Step response of the optimised speed control circuit

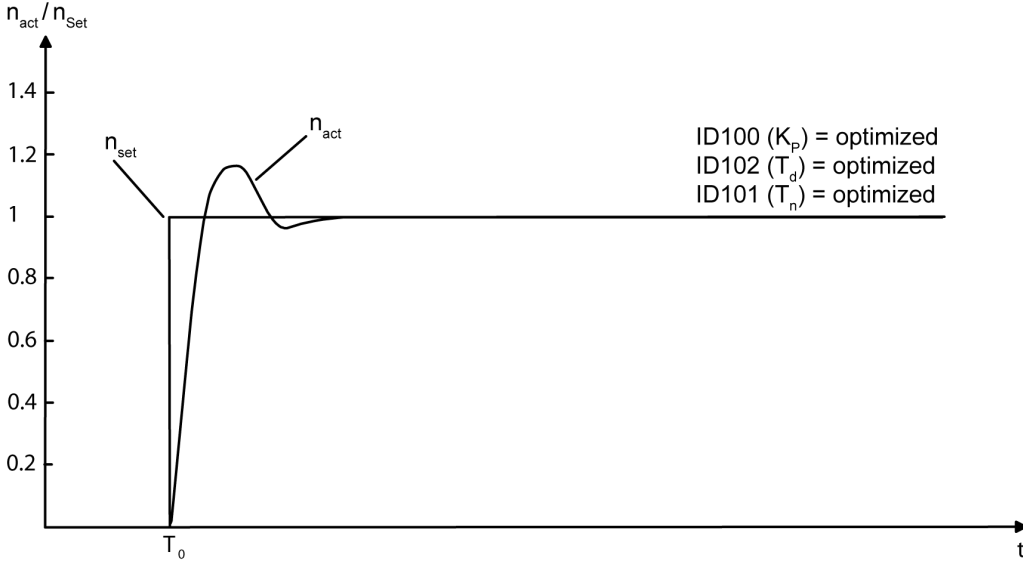

For an optimally set PID controller, the actual speed value may overshoot a setpoint step-change by no more than 20%.



Two PT1 filters can be configured at the output of the speed controller.
 See ID32928 'Time filter 1' and ID32929 'Time filter 2'

Relevant parameters:

Parameter	Name
ID100	'Speed control proportional gain KP'
ID101	'Integral-action time speed control TN'
ID102	'Differentiating time speed control TD'
ID32928	'Time filter 1'
ID32929	'Time filter 2'

Setting the proportional gain K_p

Set ID102 ('Differentiating time speed control TD', T_d) and ID101 ('Integral-action time speed control TN', T_n) to 0, the controller then works as proportional controller.

By increasing ID100 'Speed control proportional gain KP' K_p , the controller should be made to overshoot (50 % overshoots). The actual speed has a course then similar to the curve with the solid line:

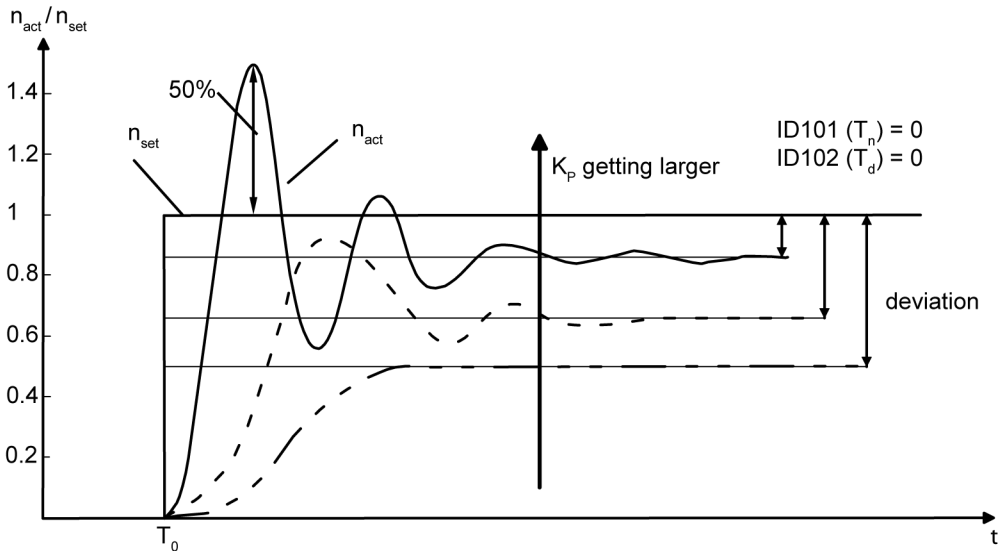

Halve the determined value for 'Speed control proportional gain KP' K_p and enter the halved value in ID100.

Setting the reset time T_n

Using the integral proportion (I-proportion) in the controller, the controller deviation resulting from the P controller is adjusted. The integration time is reduced (starting at an initial value e.g. 100ms) until the settling time is minimal. If the reset time is set optimally, the actual speed value curve (jump answer) roughly follows the curve with the solid line:

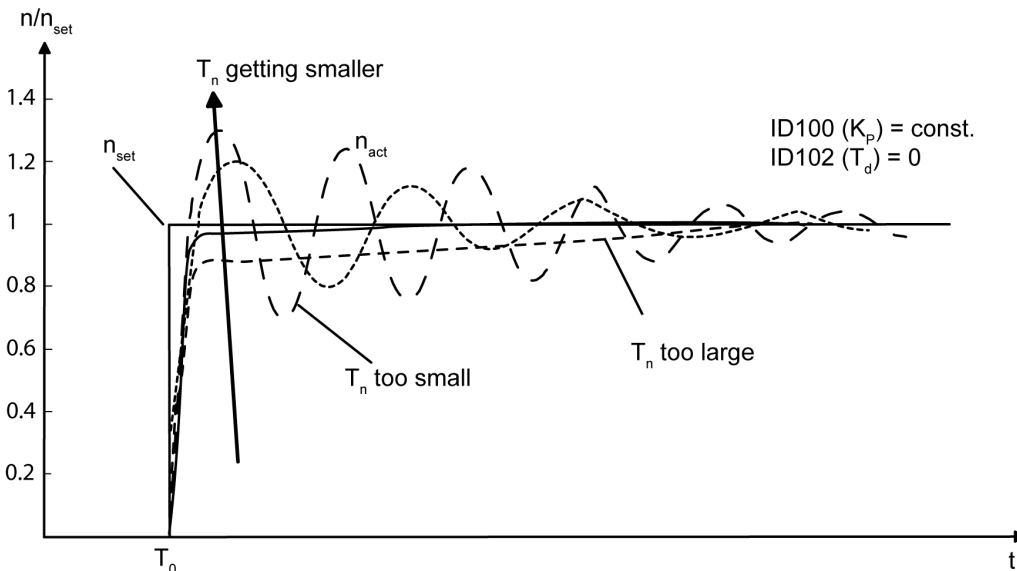

For an optimally set PI controller, the actual speed value may overshoot a setpoint jump by no more than 20% as an answer.

Setting the differential time T_d

The differentiating time T_d is extended until the desired dampening of the jump answer is reached. The curve with the solid line serves as a reference point for setting the D-share.

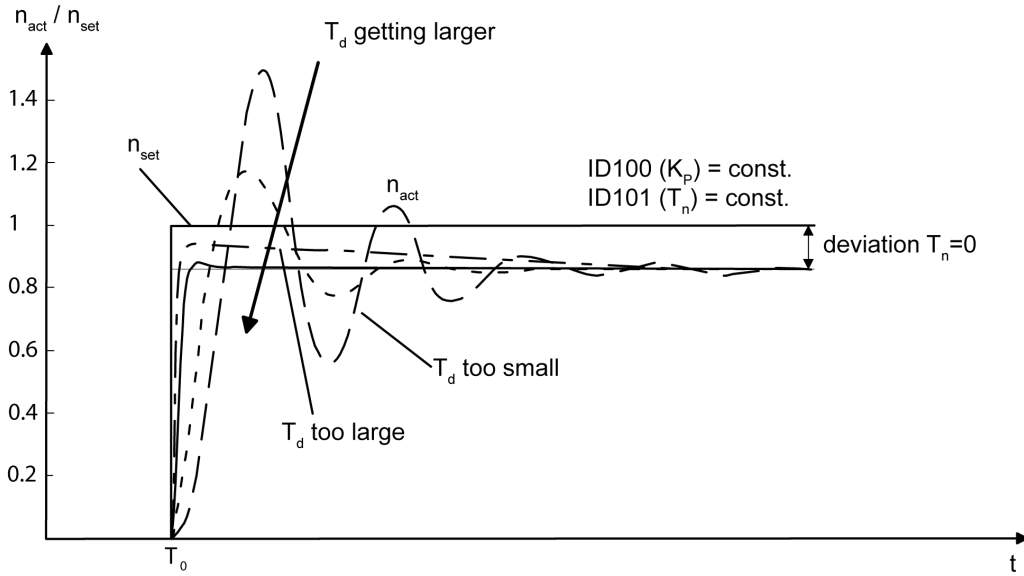

9.6.2 AIPEX PRO settings

Configuring the oscilloscope

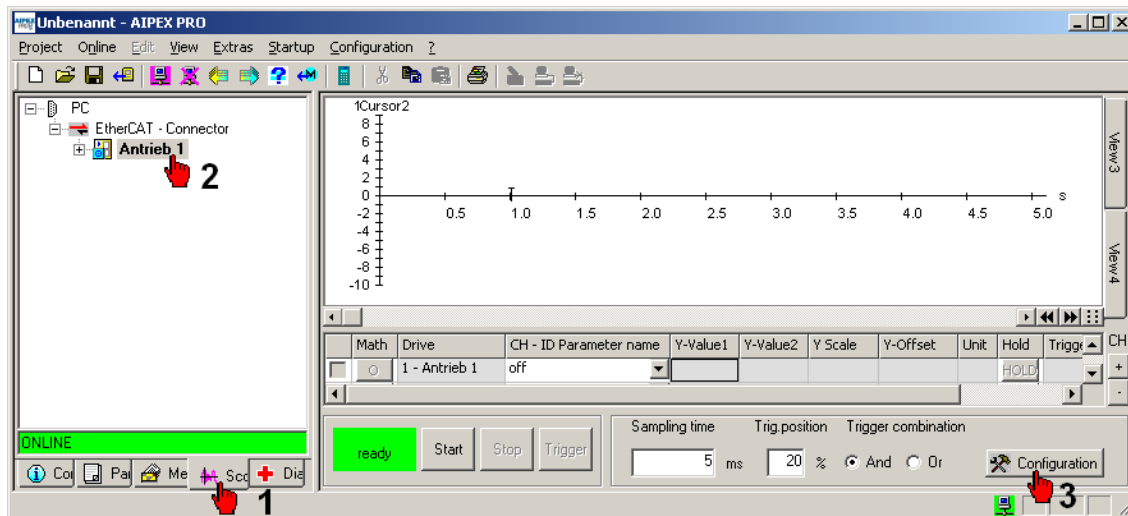

Open the 'Channels configuration' window (3).

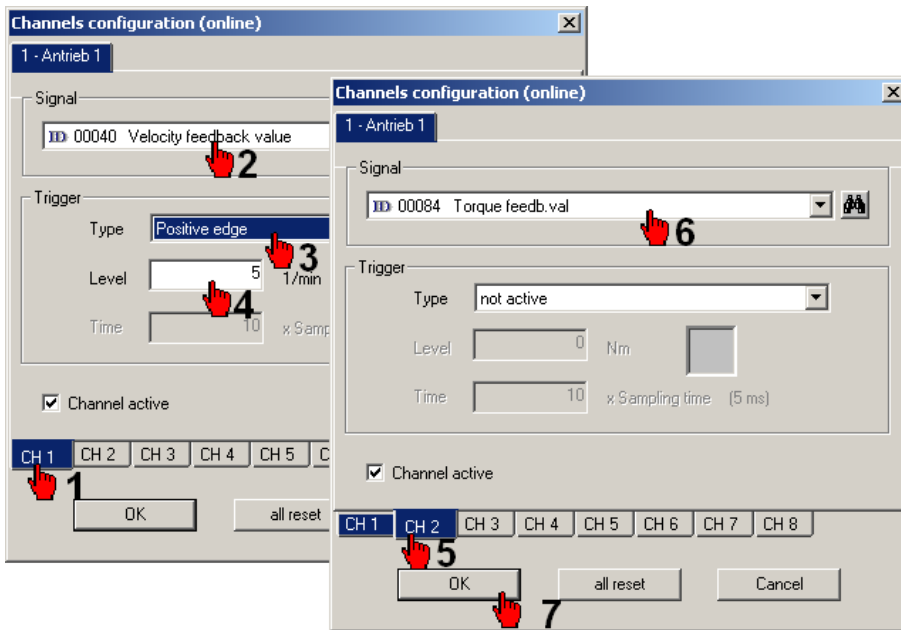

CH1:

- Signal: ID40 'Velocity feedback value'
- Trigger:
 - Type: Positive edge
 - Level: 5 1/min (the recording is started when the actual speed value exceeds 5 rpm)

CH2:

- Signal: ID84 'Torque feedback value'
- Trigger: not active

CH3:

- Signal: ID34299 'Velocity setpoint in control'
- Trigger: not active

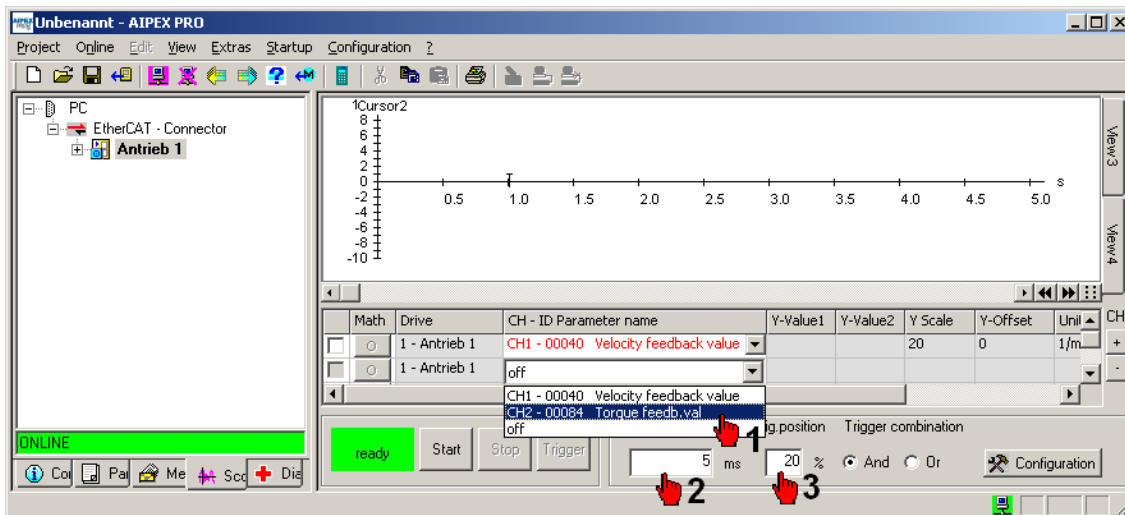

Activate the configured signals by the pull-down menu 'CH - ID Parameter name'

Configure 'Temporary parameters...'

Open the 'Temporary parameters...' window in the 'Startup' menu.

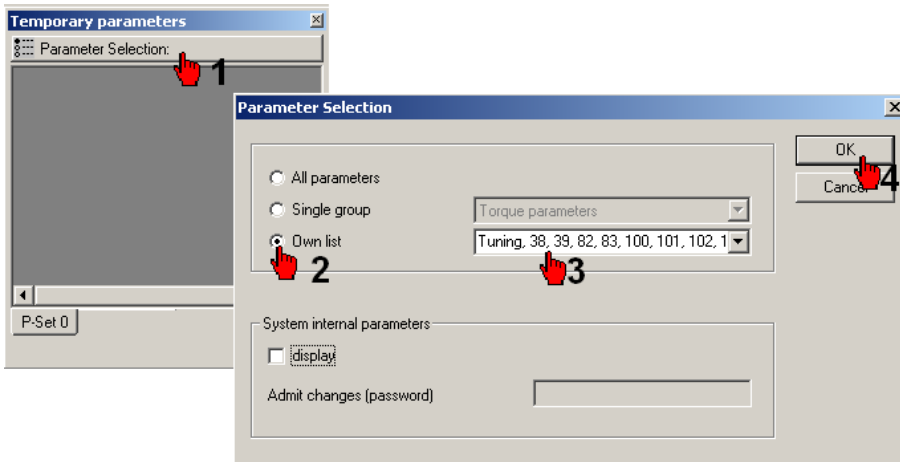
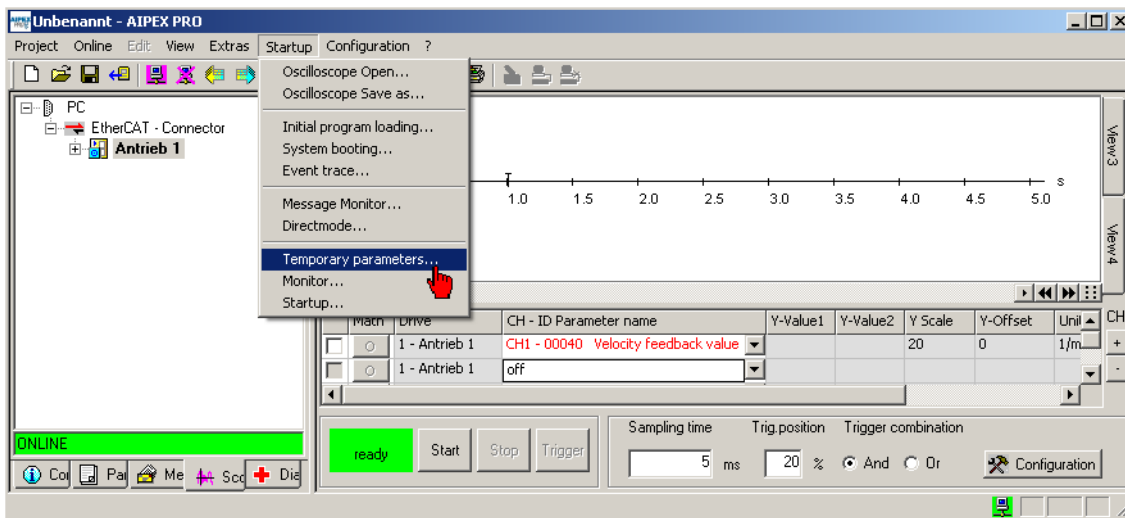

Configure your 'Own list' by entering a name and the parameter IDs which are relevant for the controller settings.

We recommend the following input:

>own list name<,38,39,82,83,100,101,102

Display own list 'Tuning':

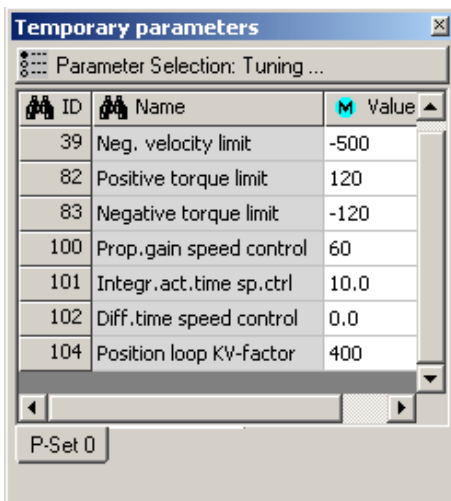

Configure startup function



The follow described function generator is not supported in the Formula Student firmware. The setpoint must be specified with the CAN controller.

Open 'Startup...' in the 'Startup' menu

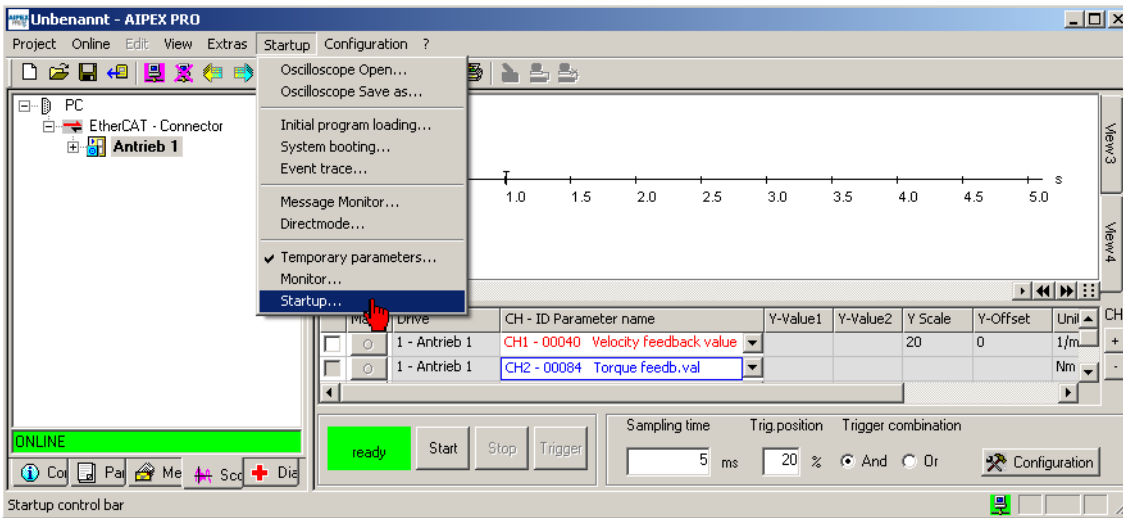

Select 'Rectangle setpoint' as speed setpoint step-change.



The following measured actual torque value has always to be less than the set torque limits. If the torque limits are exceeded, the value of 'Amplitude High (Ah)' must be reduced. Recommended start value: 100 1/min

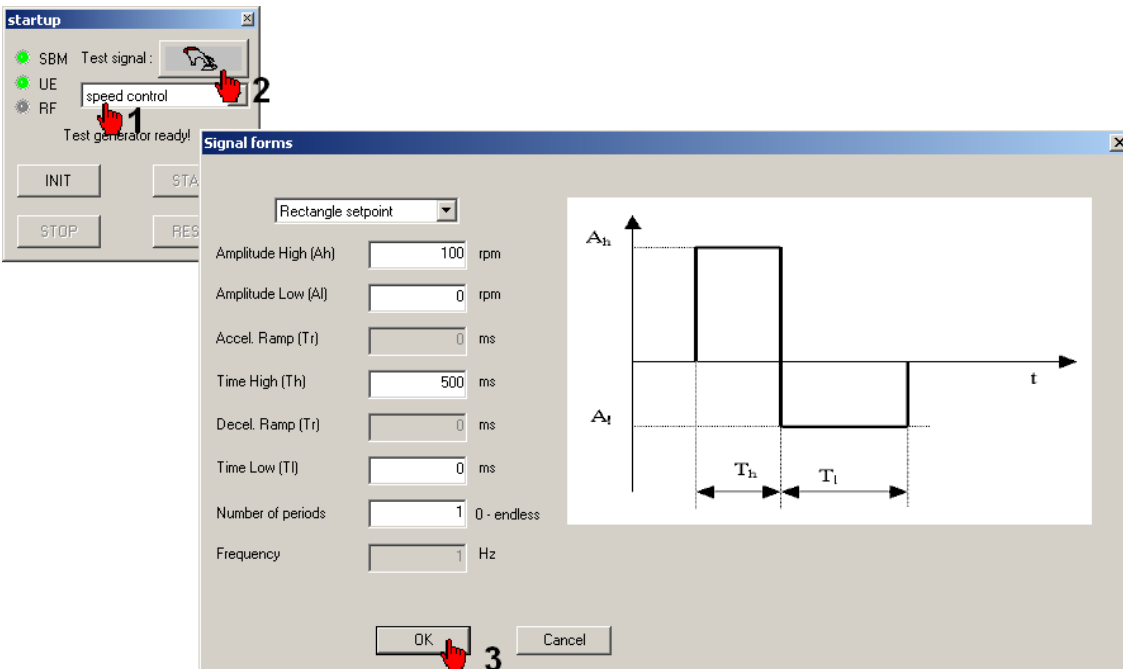

9.6.3 Optimising the speed controller

Repeat the steps to optimize the speed controller until the controller behaviour meets your idea of dynamic and rigidity.

In the 'Temporary parameters' window, you can enter the parameter values before you take a new measurement. The input is directly valid.

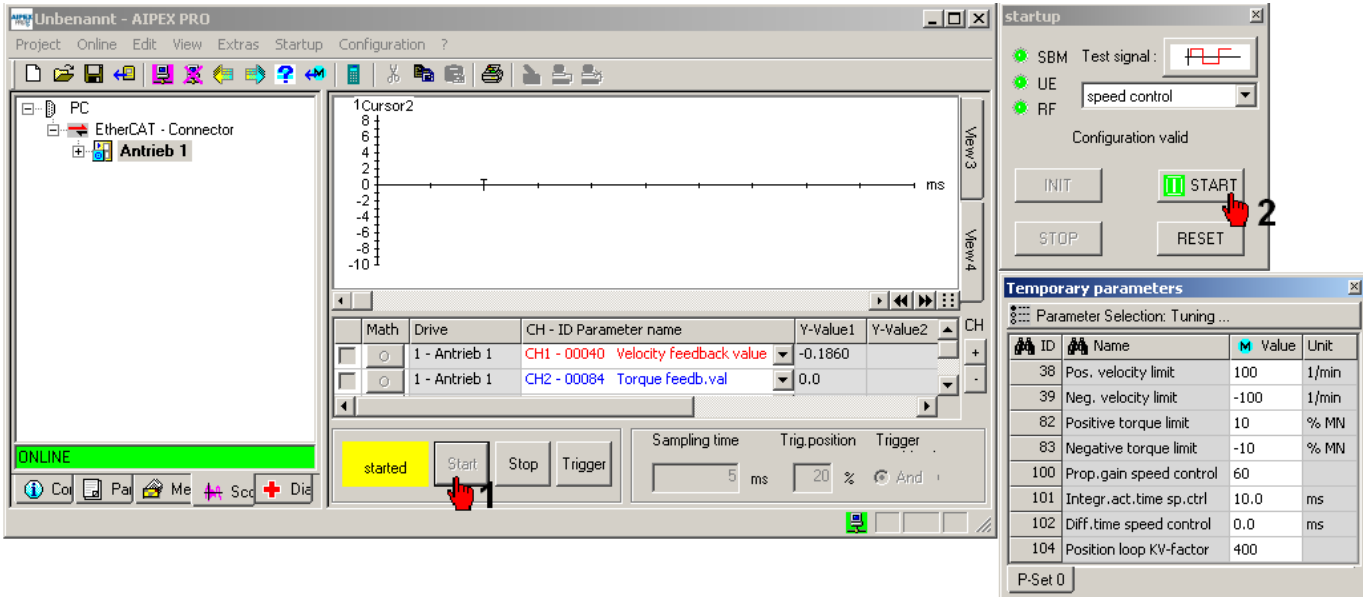

After the measurement has finished, the results are transferred to the PC and displayed automatically.

Interpret the measurement.

By means of 'Temporary parameters', you can optimise the P part (ID100), I part (ID101), and D part (ID102).

The button 'HOLD' saves the selected value so that you can compare it to the next measurement.



9.7 Error diagnosis with AIPEX PRO

With 'Diagnostics', the diagnostic messages can be read out from the selected device.

Click on each message to receive an explanation for it. You get further information if you analyse Info (I), I2 and I3

The first message of the list is the main activator of the fault; further displayed numbers might be resulting errors which will not appear any longer after rectifying the cause of the first diagnostic message.

Button 'New reading'

Diagnostic messages will be read out from the selected device.

Button 'Error reset'

The errors will be deleted in the selected device .

Button 'Error reset - via BUS'

The errors of all devices of a bus line will be deleted. To do this, select the bus in the device tree.

After the causing error is rectified successfully, 'Error reset' activates a system restart and the system ready message SBM is set.

Diagnosis with AIPEX PRO (tab 'Diagnostics')

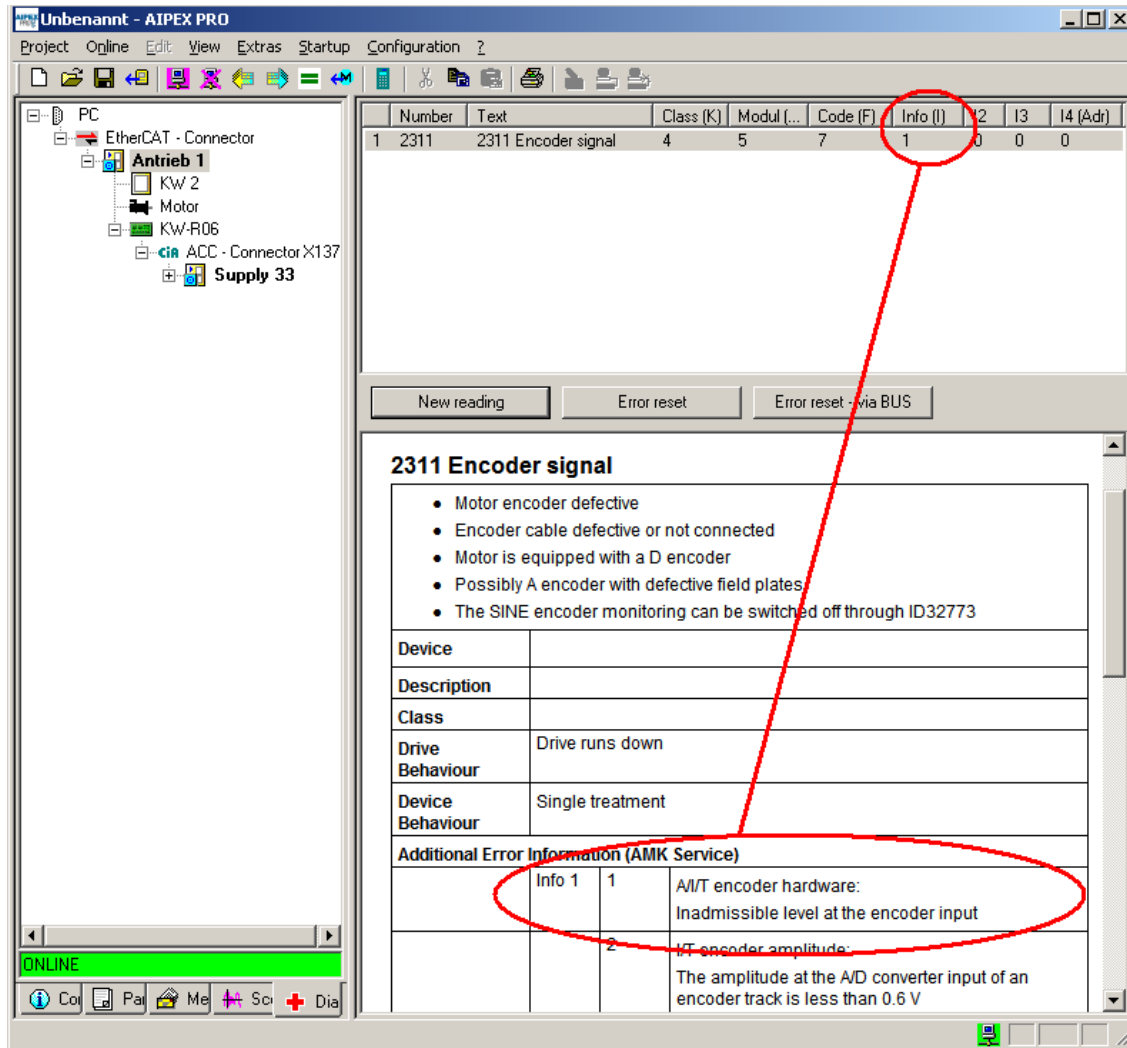

Diagnosis in direct mode

2311 Encoder signal

- Motor encoder defective
- Encoder cable defective or not connected
- Motor is equipped with a D encoder
- Possibly A encoder with defective field plates
- The SINE encoder monitoring can be switched off through ID32773

Device		
Description		
Class		
Drive Behaviour		Drive runs down
Device Behaviour		Single treatment
Additional Error Information (AMK Service)		
Info 1	1	A/D encoder hardware: Inadmissible level at the encoder input
	2	A/D encoder amplitude: The amplitude at the A/D converter input of an encoder track is less than 0.6 V (normal level: 2 V). Filtration: 5x within 50 ms leads to shutdown.

10 Certificates

The certificates are available through AMK sales or on the AMK website.

- Declaration of conformity

You can get it as follows:

- AMK homepage - service - download - registration - start online documentation - certificates
(One-time manual activation by AMK sales department is necessary.
The auto-registration via AMK homepage does not include access to the entire documentation.)

www.amk-group.com/en/content/download_area



Glossary

A

AIPEX

AMK startup and parameterizing software (PC software):
Programming, parameterization, configuration, diagnosis,
oscilloscope, status information

ATF

AMK Tool Flasher (PC software for transferring firmware to
device)

AWG

American Wire Gauge (Coding of wire diameter)

B

BA

Binary output

BE

Binary input

C

CAN

Controller Area Network

COB-ID

Communication Object Identifier (Address of a telegram in
CANopen protocol)

D

Default

Factory setting

E

ESD

Electrostatic discharge

EnDat 2.2

Motor encoder interface protocol of the company Heidenhain

EnDat 2.1

Motor encoder interface protocol of the company Heidenhain

EMC

Electromagnetic compatibility

EF

Power output stage enable

EGB

Electrostatic endangered component

EF2

Power output stage enable

EtherCAT

Real-time Ethernet bus

EMV

Electromagnetic compatibility

F

Firmware

System software, loaded by AMK

G

GND

Ground potential

H

HV

High voltage; DC bus

I

I/O

Input / output

i^2t

Integral of the squared current over time

ID

Parameter identification numbers acc. to SERCOS Standard

IGBT

Power electronic component, e. g. transistor

K

KP

Proportional gain (speed control, PID controller)

KW

AMKASYN compact inverter

KW-Rxx

AMKASYN controller card for installation into compact inverter

KTY

Type of a temperature sensor

M

MCE

Motor Controller Electronic

P**Parameter**

Identification number acc. to SERCOS standard

PDK_XXXXXX_abcdefgh

Product documentation; XXXXXX - AMK part no. , abcdefgh - name

Q**QRF**

Acknowledgment controller enable; the drive is controlled in the activated operation mode

R**RF**

Command 'Controller enable'; the drive is energized and will be controlled depending on the selected operation mode. Controller enable can only be set if the device is error-free (SBM = TRUE) and acknowledgement DC bus on is set (QUE = TRUE). Acknowledgement controller enable (QRF) is set.

S**SBM**

System ready message; shows that the device is error-free In case of error. SBM will be reset

SoE

Servodrive Profile (SERCOS) over EtherCAT (Acc. to IEC 61800-7-300)

T**Td**

Differentiating time in speed control (PID controller)

Tn

Integral-action time in speed control (PID controller)

W**WEF**

Reference potential power output stage enable

Your opinion is important!

With our documentation we want to offer you the highest quality support in handling the AMK products.

That is why we are now working on optimizing our documentation.

Your comments or suggestions are always of interest to us.

We would be grateful if you take a bit of time and answer our questions. Please return a copy of this page to us.



e-mail: Documentation@amk-group.com

or

fax no.: +49 7021/50 05-199

Thank you for your assistance.

Your AMK documentation team

1. How would you rate the layout of our AMK documentation?
(1) very good (2) good (3) satisfactory (4) less than satisfactory (5) poor

2. Is the content structured well?
(1) very good (2) good (3) moderate (4) hardly (5) not at all

3. How easy is it to understand the documentation?
(1) very easy (2) easy (3) moderately easy (4) difficult (5) extremely difficult

4. Did you miss any topics in the documentation?
(1) no (2) if yes, which ones:

5. How would you rate the overall service at AMK?
(1) very good (2) good (3) satisfactory (4) less than satisfactory (5) poor

AMK Arnold Müller GmbH & Co. KG

Phone : +49 7021/50 05-0, fax: +49 7021/50 05-199

E-Mail: info@amk-group.com

Homepage: www.amk-group.com